

CHM 335 - Physical Chemistry Laboratory
Course Syllabus
Fall 2020

Contents

1	Instructors	4
2	Teaching Assistants	4
3	Text Book	4
4	Classroom	5
5	Covid-19 Statement	5
6	Laboratory Safety	5
7	Course Requirements	5
8	Data Collection	6
9	Grading	7
10	Outline of the Laboratory Procedure	7
11	Plagiarism	8
12	Schedule	9
13	The CHM 335 Web page	10
14	The Diffusion of Salt Solutions into Pure Water	13
	14.1 Procedure	16
	14.2 Laboratory Report	19

15	Notes on Error Analysis	20
15.1	Reading Assignment	20
15.2	Introduction	20
15.3	Systematic and Random Errors	21
15.4	The Distribution of Random Errors - The Gaussian Distribution	21
15.5	Calculation of Random Errors for a Finite Set of Laboratory Measurements .	23
15.6	Error Propagation	24
15.7	Errors from a Graphical Analysis of the Data	28
16	Experiment 9(28)a: The Intrinsic Viscosity of Polyvinyl Alcohol	31
16.1	Introduction and Reading Assignments	31
16.2	Theory	31
16.3	Experimental Procedure	32
16.4	Laboratory Report	32
17	Experiment 9(28)b: The Intrinsic Viscosity of Polyvinyl Alcohol	34
17.1	Introduction	34
17.2	Theory	34
17.3	Cleaning Procedure	35
17.4	Laboratory Report	35
18	Format of Laboratory Reports for Remaining Experiments	36
19	Experiment 7(13) - The Vapor Pressure of a Pure Liquid	37
19.1	Reading Assignment	37
19.2	Experimental Notes	37
19.3	Laboratory Report	39
20	Experiment 6(11) - Freezing-point Depression of Strong and Weak Electrolytes	39
20.1	Reading Assignment	39
20.2	Experimental Notes	39
20.3	Calculations	40
20.4	Error Analysis	41
20.5	Discussion	41
21	Experiment 6 - The Heat of Combustion of Organic Compounds	41
21.1	Reading Assignment	41
21.2	Experimental Notes	41
21.3	Error Analysis	41

22 Experiment Number 3(3) - Heat Capacity Ratio of Gases	42
22.1 Reading Assignment	42
22.2 Theoretical Discussion	42
22.3 Experimental Notes	46
22.4 Laboratory Report	46
23 Experiment 8(25) - Surface Tension of Solutions	47
23.1 Theory	47
23.2 Experimental Notes	52
23.3 Laboratory Report	53
23.4 Calculations	53
24 Tables of Data	56

1 Instructors

1. Prof. Dugan Hayes (Tuesday and Thursday's Sections)
374 E Beaupre
Phone: 874-5516
Office Hours: Tu,Th 10
e-mail:dugan@uri.edu
2. Prof. David L. Freeman (Wednesday and Friday's Sections)
474 C Beaupre
Phone: 874-5093
Office Hours: MWF 10
e-mail:dfreeman@uri.edu

2 Teaching Assistants

1. Carson Hasselbrink
360 Beaupre
Office Hours: M 10
e-mail:clhassel@uri.edu
2. Missy Smith
365 Beaupre
Office Hours: W 11
e-mail: melissa-smith@uri.edu
3. Sophia Tiano
375 Beaupre
Office Hours:Th 11
e-mail: sophia_tiano@uri.edu
4. Danielle Jacoby
375 Beaupre
Office Hours: Tu 10
e-mail: djacoby@uri.edu

3 Text Book

Experiments in Physical Chemistry, Garland, Nibler and Shoemaker (McGraw-Hill, 2018)
ISBN-13:9781307253931, URI Package, Available only in the URI Bookstore

4 Classroom

280 Beaupre

5 Covid-19 Statement

Because of the COVID-19 pandemic in all classroom settings including your work in lab, at all times you must 1) keep a social distance of 6 feet from all other persons and 2) wear a face mask. Additionally, as discussed below, you must wear safety goggles in room 280 Beaupre. If you feel ill in any way, you are not to come to class. If you are feeling ill on a CHM 335 class day, you should contact both the instructor in charge of your session and the TA in charge of the experiment performed on that date. We will make accommodations for any missed work.

6 Laboratory Safety

You must wear safety glasses with side guards or safety goggles and have them on before you enter the laboratory. Of course, you must continue to wear them while in the lab. You must also wear a laboratory coat, and you may not wear open-toed shoes or sandals. Nitrile gloves will be provided at the beginning of each in-person laboratory experiment. You must wear the nitrile gloves the entire time you are in the laboratory. You must always wear a face mask while in Beaupre. Your face masks can either be cloth or disposable. If you ever are in the lab without a face mask, you will be removed from lab, and you will not be allowed to make up the experiment.. If you are ever in the laboratory without eye protection or a lab coat, you will have 5 points deducted from your next laboratory report. Repeated offenses will result in failure in the course. Be sure to bring your safety and covid equipment to the second class meeting, so that you will be allowed to perform the first experiment of the semester.

All students must complete the Department Safety and Environmental Compliance Form. All students must have their Medical Information Form with them during every laboratory period.

7 Course Requirements

This semester you are to take part in eight experiments. Most of the eight experiments are to be performed by you in the laboratory, with a few experiments either performed remotely or with data provided to you for analysis.

Some of the experiments are to be performed with a laboratory partner. **Even though you may collect data with a partner, you are responsible for your own labora-**

tory reports. Identical or nearly identical laboratory reports from two or more students are treated as cases of plagiarism.

The first experiment, to be performed during the second week of classes, is a study of the diffusion of ionic species in water. You will work with a partner. In this experiment you extract data and confirm that concentration gradients migrate with a particular functional dependence on the time. Details are given in section 14.

For the third week of classes, you will be given a lecture on error analysis. The error analysis lecture will be given remotely. Even though you have no experiment for the third week, you still need to submit your diffusion reports electronically.

In the second experiment you measure the viscosity of polyvinyl alcohol in water. The purpose of this experiment is to instruct you in the principles of experimental error. You repeat your measurements many times to observe the statistical distribution of error. Your laboratory reports on this experiment emphasize the analysis of these errors. Details are given in Section 16.

You will not actually perform the third experiment, but rather one of the graduate assistants will send you data. The third experiment again involves the viscosity of polyvinyl alcohol solutions, but after chemical degradation. The purpose is to learn structural information about the polymer from bulk measurements. The laboratory report from this experiment incorporates all sections learned in the first two experiments, and constitutes a complete laboratory report. As with all experiments, the report for this project is due one week after you receive the data.

The next two experiments are 4) the vapor pressure of a liquid and 5) the freezing point depression of weak electrolytes, which you will perform in the lab. The final three experiments are 6) the heat of combustion of organic compounds, 7) the heat capacity ratio of gasses and the surface tension of solutions, which will be performed by a TA. You will not be present for these experiments owing to problems expected ensuring social distancing; instead, you will either observe the experiment remotely, or data for the experiments will be sent to you. Whether you perform the experiments yourself or use provided data, complete laboratory reports are to be submitted for each of these experiments.

8 Data Collection

Where possible, all data generated in the laboratory should be entered into a laboratory notebook. Laboratory notebooks can be purchased in the bookstore, and the bookstore notebooks generate carbonless copies, so that a copy of your data is automatically generated. In some instances the data you generate cannot be entered into the notebook. Your TA will inform you when the notebooks are not required. The copy of your data signed by your TA should be included in the data portions of your laboratory reports.

9 Grading

Each laboratory report is worth 100 points. These reports **must be submitted electronically** and are due exactly one week after the completion of a given experiment. The reports should be uploaded before coming to class. If, because of a holiday, classes do not meet one week following the completion of an experiment, the report is due on the first day of classes following the holiday. For example, this semester Tuesday, November 3 is election day, and the University is closed. The reports for any experiment performed on Tuesday, October 27 are due on Wednesday, November 4 rather than the nominal due date of November 3. In a similar fashion, if a class is canceled because of weather (or any other reason) the report is due the day following the canceled class or the next date the University is officially open. **Reports are due at the beginning of the class on the due date. Late reports will be accepted for grading up to one week after the due date. However, late reports are assessed a penalty of 2 points for each day that they are late. Reports submitted more than one week past the due date will not be accepted for grading, and such reports will receive a score of 0.** Your laboratory reports must show all calculations, not just sample calculations of each type.

Your grades are determined on an absolute scale. The scale is

A : 745 to 800 points
A- : 720 to 744 points
B+ : 695 to 719
B : 665 to 694
B- : 640 to 664
C+ : 615 to 639
C : 585 to 614
C- : 560 to 584
D+ : 535 to 559
D : 480 to 534
F : < 480

10 Outline of the Laboratory Procedure

The following pertains to laboratory experiments, which you actually perform. For experiments either performed by your TA remotely or where data are provided by your TA, the “Procedure” sections of your reports are not required. However, the data you use must be attached.

Before being allowed to begin any of the experiments in this course, you are required to prepare an outline of the experimental procedure. You should prepare the outline at home, and bring it to class with you. Your TA then signs and dates the outline before you begin the experiment. The signed outline must be attached to your laboratory report. No laboratory reports can be graded without the attached signed outline.

At the completion of an experiment, you must present your data to your TA. The TA

then signs and dates the data. The original signed data must be attached to your laboratory reports for grading. No laboratory report can be graded without the signed data attached.

11 Plagiarism

One of our goals in this course is to reinforce the importance of scientific integrity. In recent years, there have been numerous examples of established scientists generating falsified data or copying material from another source. Acts of plagiarism both damage science and can have important impacts on society. The possibly falsified data associated with the connection between childhood vaccines and autism is an important recent example that has adversely affected both science and public health. Acts of plagiarism have destroyed many scientific careers. Consequently, we want to make clear to you what plagiarism is and penalize acts of plagiarism in a manner that makes clear its seriousness.

Your laboratory reports contain information about the purpose, theory and results of your experiments. Each of you prepares a laboratory report associated only with your name. By implication you are the sole author of that report, and no section of your report can be identical (or nearly identical) to that of another person without attribution. Reports or sections of reports identical to any other source whether that source be another student, a section of a book, or information obtained from others on the web is treated as plagiarism. In CHM 335 the first instance of plagiarized sections are to receive a grade of 0. For repeat instances of plagiarism, the entire report will receive a 0. Any clear incidence of plagiarism will be reported to the Dean of the appropriate college, the Dean of Arts and Sciences and the Chemistry Department Chair.

In CHM 335 there is one exception to this policy. You often generate your data with a laboratory partner or data are provided to you. The original data included in your reports, and only the original data, should be identical to that of your laboratory partners. The other sections of your reports, including all written work and all calculations cannot be identical to anyone including your laboratory partners.

As an example in the first experiment of the semester you determine the diffusive behavior of ionic salts in water. The data from this experiment consists of a sheet of graph paper with multiple curves in different colors generated as a function of time. At the end of the experiment each set of partners has one sheet of graph paper with the same curves. The data is then photocopied in color, and each partner receives either the original sheet or the photocopy. This original data should be included in each partner's laboratory report, and the data are clearly identical for each partner.

To analyze this data each partner must separately generate numbers from the graphs using a ruler and a set of points on the graph chosen by each individual in a manner to be discussed later this semester. It is impossible for the generated numbers to be identical between partners even though the curves are identical. Identical generated data from this experiment or any other experiment is an example of plagiarism.

Another possible source of plagiarism can occur if you do not analyze your data by yourself. Students often work together, and the plagiarism policy is not designed to discourage

collaborative learning. However, in the end, your calculations must be your own done in your unique fashion. The sections of your reports containing the calculations must not be identical or nearly identical to anyone else. From experience it is not possible for any two people analyzing the same data to obtain exactly the same set of calculations in the same order with the same final results. To avoid even the appearance of plagiarism, if you decide to study with another student, you must perform your calculations by yourself or with the help of one of the instructors. Nearly identical calculation sections are examples of plagiarism.

12 Schedule

1. Week 1: Lecture and Orientation (Virtual Lecture)
Tuesday - Sept. 15
Wednesday - Sept. 9
Thursday - Sept. 10
Friday - Sept. 11
2. Week 2: The Diffusion of Salt Solutions
Tuesday - Sept. 22
Wednesday - Sept. 16
Thursday - Sept. 17
Friday - Sept. 18
3. Week 3: Virtual Error Analysis Lecture
Tuesday - Sept. 29
Wednesday - Sept. 23
Thursday - Sept. 24
Friday - Sept. 25
4. Week 4: The Viscosity of Polyvinyl Alcohol, Part a
Tuesday - Oct. 6
Wednesday - Sept. 30
Thursday - Oct. 1
Friday - Oct. 2
5. Week 5: The Viscosity of Polyvinyl Alcohol, Part b (No experiment - data to be provided by TA)
Tuesday - Oct. 13
Wednesday - Oct. 7
Thursday - Oct. 8
Friday - Oct. 9
6. Week 6: Vapor Pressure of a Pure Liquid
Tuesday - Oct. 20

Wednesday - Oct. 14

Thursday - Oct. 15

Friday - Oct. 16

7. Week 7: Freezing Point Depression

Tuesday - Oct. 27

Wednesday - Oct. 21

Thursday - Oct. 22

Friday - Oct. 23

8. Week 8: Heat of Combustion of Organic Compounds (remote experiment)

Tuesday - November 10

Wednesday - Oct. 28

Thursday - Oct. 29

Friday - Oct. 30

9. Week 9: Heat Capacity Ratio of Gases (remote experiment)

Tuesday - Nov. 17

Wednesday - Nov. 4

Thursday - Nov. 5

Friday - Nov. 6

10. Week 10: Surface Tension of Solutions (remote experiment)

Tuesday - November 24

Wednesday - November 18

Thursday - November 12

Friday - November 13

13 The CHM 335 Web page

It is expected that for most of you, success in this course will require some level of help beyond classroom instruction. Because some of you may find it difficult to come to the scheduled office hours, we have installed web pages, including a page that can be used to submit questions. Our course web page can be found at <http://www.chm.uri.edu/courses/?chm335&1>. Questions are submitted by anyone in the class by filling out a form on the web page, and answers are distributed either to the entire class or only to the person asking the question. If the entire class is to receive a copy of the question and answer, the question is treated as anonymous; i.e. the person who asks the question is never identified. In fact, it is possible to submit a question so that even the instructor does not know who submitted the question. Anonymous questions and responses by the instructor are distributed automatically to everyone in the class. With ordinary electronic mail, there is a private correspondence between the student and instructor. By using the web page, the entire class has an opportunity to learn from the questions submitted.

The use of the web page does not preclude personal interaction between any of you and the course instructor. Dr. Freeman, Dr. Hayes and the teaching assistants all have regular office hours, and you are all encouraged to make use of these hours. Alternate meeting times can be arranged by appointment. Additionally, you can contact the instructors by e-mail or telephone. The e-mail addresses and phone numbers for all the instructors are given in this syllabus.

Any student in CHM 335 can submit questions and comments to the instructors. Submission of such comments or questions must be made using the WWW home page for this course. The address (URL) of our home page is

<http://www.chm.uri.edu/courses/?chm335&1> . To submit a question to the list, you must click on the highlighted text that says “submit a question to the CHM 335 list.” As an example of how to use the list, suppose a student in our class, Ms. Benzene Ring, wonders, “How do I propagate errors for $\ln p$ where p is the pressure?” (If you don’t know what this means, don’t worry. You will understand the question later in the semester). To obtain an answer to her question, Ms. Ring links her web browser (e.g. Safari, Chrome, Firefox or Microsoft Internet Explorer) to <http://www.chm.uri.edu/courses/?chm335&1>, and she then clicks on the text linking her to the page for questions (i.e. the highlighted text that says “submit a question to the CHM 335 list”). Ms. Ring then enters her e-mail address in the appropriate box and specifies whether she wants her question to be answered to the entire CHM 335 class or to her alone. Ms. Ring then types in the large box

How do I propagate errors for $\ln p$ where p is the pressure?

Ms. Ring then clicks the “send” button. Ms. Ring’s question is received by the course instructors. One of the instructors then sends an e-mail message to the whole list that might be

Subject: errors

The question is: How do I propagate errors for $\ln p$ where p is the pressure?

Answer: Take the differential. Let $y = \ln p$. Then $dy = dp/p$, and the error in y ($\ln p$) is given by $e(y) = e(p)/p$ where $e(y)$ means the error in y .

Now Ms. Ring and the entire class have an answer to her question.

If the answer to the question can be sent to the entire list, the answer will not indicate who asked the question. If Ms Ring wants to ask the question with full anonymity so that even the instructors have no idea who asked the question, the e-mail portion of the form can be left blank. Of course, if the e-mail section of the form is blank, the answer must be sent to the list and not just to the sender.

Because many questions may contain mathematical formulas, we need a notation to communicate the special symbols used in the course. To avoid confusion, it is most useful if we agree on the same set of symbols. The symbols that follow are taken from a language called \LaTeX . \LaTeX is a language that is frequently used to prepare scientific documents, and \LaTeX can be used to translate special symbols into simple text characters. By learning \LaTeX notation, you will learn a widely used method to communicate mathematical symbols via e-mail. The instructors plan to use these symbols in answering your questions, and it is

asked that you use the same symbols in posing questions. The most important symbols are the following:

1. Greek letters are represented by `\` followed by the name of the letter. For example α is typed `\alpha`, β is typed `\beta`, and so on. A Greek letter is made upper case by making the first letter of its name upper case. For example, the letter Δ is typed `\Delta`.
2. Subscripts are represented by `_{}` where the brackets contain the subscripts. For example, μ_{ij} is typed `\mu_{ij}`.
3. Superscripts are represented by `^{}` where the brackets contain the superscripts. For example, β^{12} is typed `\beta^{12}`.
4. Infinity (∞), is typed `\infty`.
5. The integral sign \int is typed `\int`. The limits on a definite integral are included by introducing subscripts and superscripts. As an example $\int_0^\infty e^{-x^2} dx$ is typed `\int_{0}^{\infty} e^{-x^2} dx`.
6. The partial derivative symbol ∂ is typed `\partial`.
7. The summation sign \sum is typed `\sum`. The lower and upper limits of summation are included as subscripts and superscripts. As an example $\sum_{n=0}^\infty 1/n^2$ is typed `\sum_{n=0}^{\infty} 1/n^2`.
8. Square roots $\sqrt{a+b}$ are typed `\sqrt{a+b}`.
9. The arrow in chemical reactions \rightarrow is typed `--->`. For example $C+O_2 \rightarrow CO_2$ is typed `C + O_2 ---> CO_2`.

Let us now look at another example of a question submitted using the web. In this case, Ms. Ring has a question requiring an equation. This might be a real question. If you don't understand the context, don't worry. You will understand the details of the question later in the course. Suppose Ms. Ring wants to ask

“In deriving the expression for the phase equilibrium line between gas and liquid, when evaluating the integral expression

$$\ln \frac{p_2}{p_1} = \int_{T_1}^{T_2} \frac{\Delta H}{R T^2}$$

ΔH is taken outside the integral. What is the justification for this?”

To submit the question, Ms. Ring uses her web browser to navigate to <http://www.chm.uri.edu/courses/?chm335&1>, clicks on the line that says, “submit a question to the CHM 335 list,” and then Ms. Ring enters the information requested by the form.

If Ms. Ring wishes to remain anonymous, Ms. Ring leaves the e-mail box blank. Ms. Ring then types into the large box

In deriving the expression for the phase equilibrium line between gas and liquid, when evaluating the integral expression

$$\ln p_2/p_1 = \int_{T_1}^{T_2} (\Delta H/R) dT/T^2$$

ΔH is taken outside the integral. What is the justification for this?

and clicks on the submit button. Ms. Ring's question is received by the course instructors.

The answer will be sent either to Ms. Ring alone, or preferably to the entire class if the appropriate box is checked. One of the instructors might reply

Subject: Experiment Number 13 Question

The question is: In deriving the expression for the phase equilibrium line between gas and liquid, when evaluating the integral expression

$$\ln p_2/p_1 = \int_{T_1}^{T_2} (\Delta H/R) dT/T^2$$

ΔH is taken outside the integral. What is the justification for this?

The answer is: ΔH is only weakly dependent on temperature. Then enthalpy change can be taken outside the integral to a good approximation.

14 The Diffusion of Salt Solutions into Pure Water

When a drop of ink is placed in a beaker of water, the ink is observed to migrate from the initial location of the ink drop to the remainder of the water. This migration is called *diffusion* and continues until the ink concentration is uniform throughout the solution. In this experiment we study the time dependence of one property of the diffusion process.

Instead of a drop of ink, you use an ionic solution and let it diffuse into pure water to determine how the ionic concentration gradient depends on time. You begin with a rectangular cell with the bottom half filled with the salt solution and the top half filled with water as depicted in Figure 1. As time passes, the salt in the concentrated layer migrates to regions of low salt concentration. If the salt concentration c is measured as a function of time t and coordinate x [See Figure 1 for the definition of x], the concentration profile appears as in Figure 2 [c_0 is the initial salt concentration in the salt rich layer]. The two lines drawn in Figure 2 represent concentration profiles at two different times. Can you tell which of the two times is earlier? Using Fick's Law of Diffusion [See Engel and Reid, Sections 17.2 through 17.4], it is possible to show that

$$\frac{\partial c}{\partial x} = Ae^{-x^2/2\sigma^2(t)} \quad (1)$$

where A is a constant and σ is called the *standard deviation*. Equation (1) is often called a Gaussian distribution. A graph of Eq.(1) is shown in Figure 3. The standard deviation σ is a measure of the width of the distribution. It is possible to show that the area under a Gaussian between $-\sigma \leq x \leq \sigma$ comprises $\sim 68\%$ of the total area under the Gaussian curve.

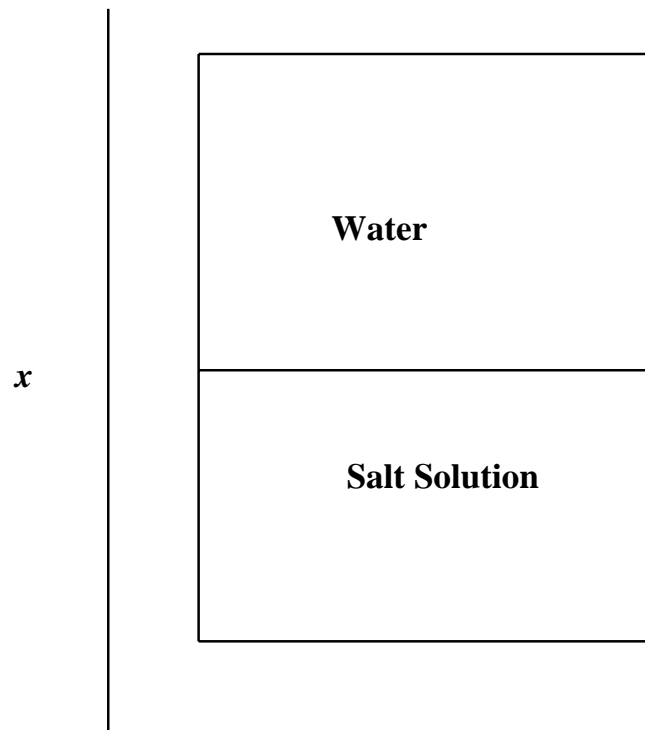

Figure 1

Figure 2

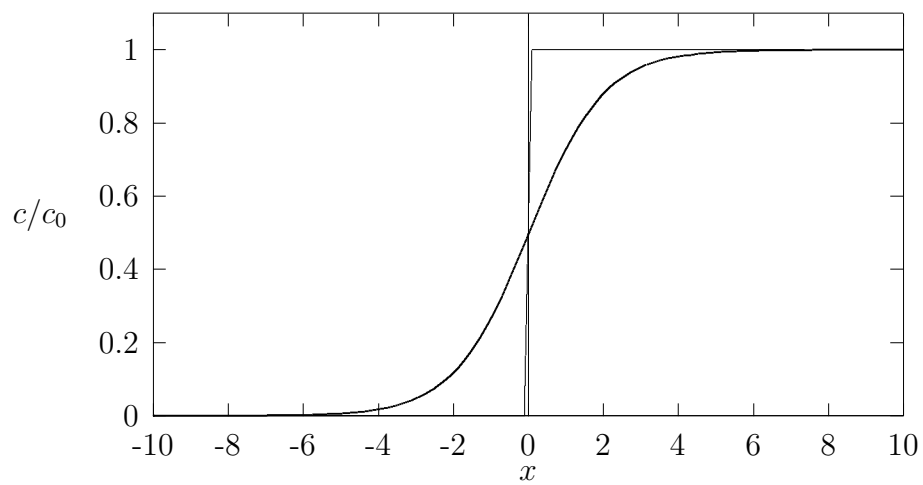
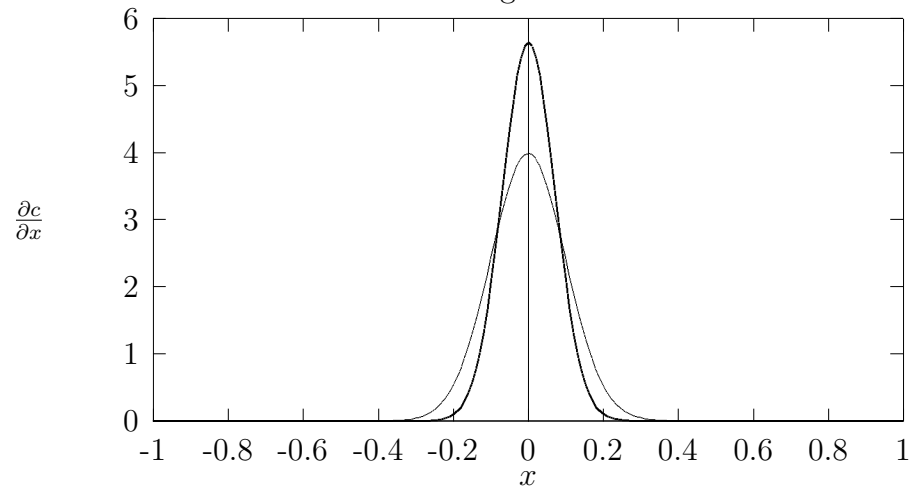

Figure 3



Therefore, if σ is large [the light line in Figure 3], the distribution is wide and if σ is small [the dark line in Figure 3] the distribution is narrow.

In this experiment you measure σ directly in a diffusion cell as a function of time. You can be expected to find that

$$\sigma = Kt^\alpha \quad (2)$$

where K and α are constants. Relations of the form of Eq. (2) are often called *power laws*. You should find that α is particularly simple.

The method you will use to determine the concentration gradient of the solution as a function of time is based on the refraction of light. When light travels from one medium to another, the light bends. This bending of light is called *refraction*. In common experience, if a spoon is placed in a glass of water, it appears bent because of refraction. The amount that light is bent is proportional to a property of a medium called the *index of refraction* n . In a salt solution, the index of refraction depends on the type of ionic species and the concentration of the solution. In our cell where there is a concentration gradient, the index of refraction depends on the coordinate x . Since the index of refraction is proportional to the concentration, it is easy to see that

$$\frac{\partial c}{\partial x} = K' \frac{\partial n}{\partial x} \quad (3)$$

where K' is a constant of proportionality. We can then measure the concentration gradient by measuring the gradient of the index of refraction.

In this experiment the index of refraction gradient is measured by passing a laser light beam perpendicular to a glass stirring rod that acts as a cylindrical lens. The stirring rod is set at an angle of about 45 degrees to the horizon. The resulting light image is projected onto the surface of the diffusion cell. The line is at an angle of approximately 45 degrees to the horizontal axis of the cell and perpendicular to the direction of the glass rod. If the line of light is passed through a solution of uniform concentration, the image on the other side of the diffusion cell, that we project on to a screen, is parallel and longer than the incoming image. However, if the solution has a concentration gradient, the component of the incoming light in the x direction deflects by differing amounts depending on the concentration gradient. The resulting projected image appears as in Figure 4. In Figure 4, the straight line represents the image that appears in a solution of uniform concentration, and the curved line represents the image that appears if the solution has a concentration gradient. At any location along the abscissa, X' in the graph is proportional to the coordinate x in the cell and the difference $\Delta X'$ is proportional to the concentration gradient. A plot of $\Delta X'$ as a function of X' then is a Gaussian distribution. The dependence of the standard deviation of the resulting Gaussian on time is the same as the dependence of the standard deviation in Eq. (1) on time. Consequently, we can work with the plotted data directly.

14.1 Procedure

1. Make up 2 M solution of the salt given to you. Record in your laboratory notebook the name of the salt. Be sure to stir the solution thoroughly to completely dissolve the

Figure 4

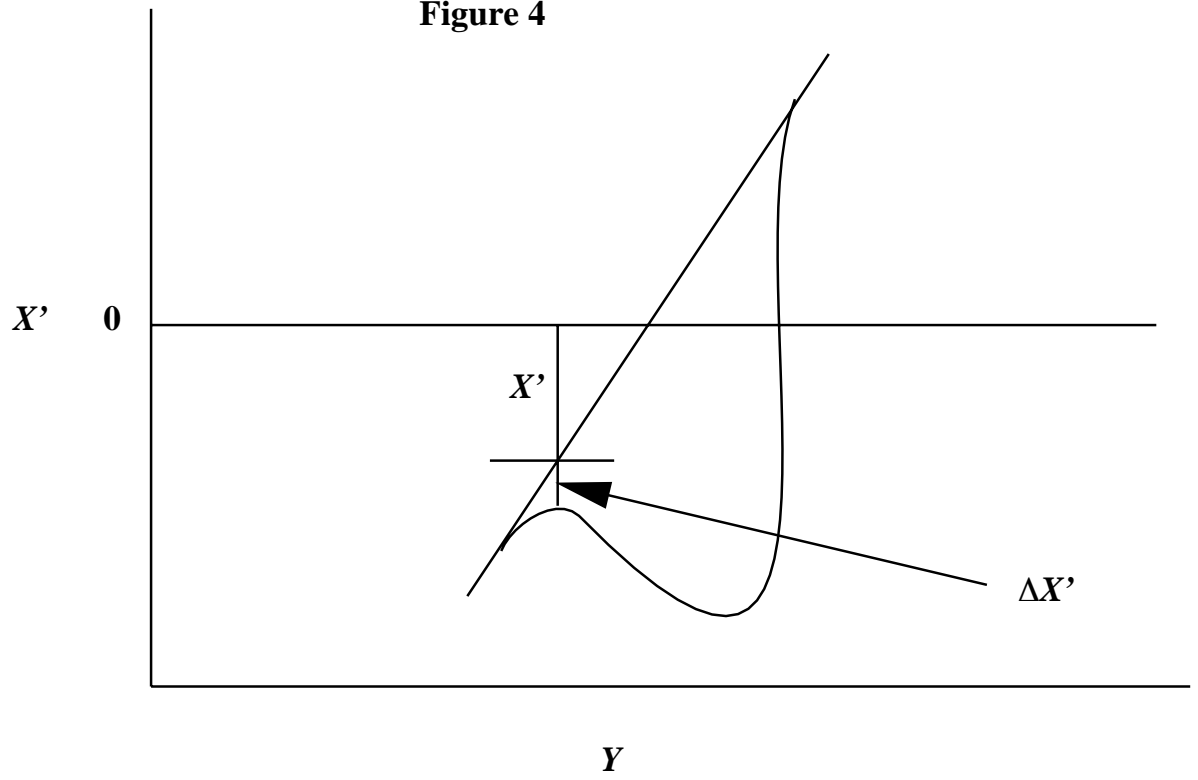

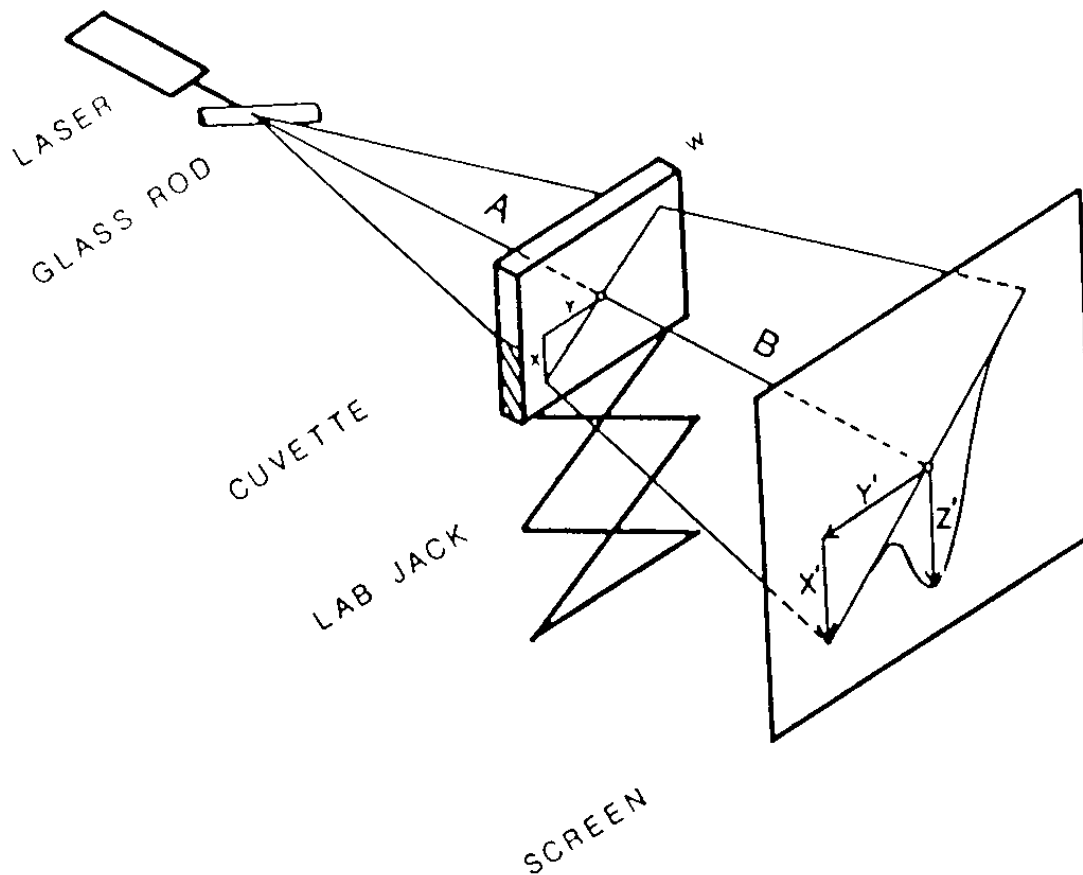

Figure 3. Line drawing of the experimental apparatus.

salt in water.

2. You begin this experiment by solving a simple riddle qualitatively. Fill a 50 ml beaker with distilled water and another 50 ml beaker with your salt solution. Imagine that you have no idea which beaker contains water and which contains the salt solution. Given only a pipette and pipette bulb, you are to determine which beaker contains the water and which contains the salt solution.
3. For the main part of this laboratory, the experimental components consist of a low power helium-neon laser, a cylindrical lens made from a glass rod, a cuvette (diffusion cell) on a laboratory jack, and a piece of graph paper that is to be used as a screen. The glass rod, the cuvette and the screen are mounted perpendicular to the laser beam as shown in Figure 5. To scan several depths in the cuvette simultaneously,

the beam of light from the laser is fanned through the glass stirring rod mounted at about 45 degrees to the horizontal. The rod is placed so that its edge is a distance of approximately 40 cm. from the center of the cuvette. The cuvette is mounted on a laboratory jack to facilitate vertical positioning. The graph paper screen is placed on the wall at the end of the lab bench.

4. Fill the cell halfway with the salt solution.
5. Raise or lower the cell until the laser hits the meniscus. A vertical line will appear on the screen. Trace this line.
6. Slide the ring stand with the glass rod attached back so that the rod is between the cuvette and the laser making a line at a 45 degree angle. Trace the diagonal laser line on the graph paper.
7. Add water to the cuvette by using a pipette and a floating cork. Make sure the water is added slowly and directly on the cork so as not to disturb the interface. This process should take a few minutes. You should start your stopwatches at the time you begin to add water to the cuvette.
8. When you have waited sufficient time so that a stable curve appears entirely on your graph paper, trace the curve on the graph paper and note the time.
9. Trace new lines at 5 minute intervals for 40 minutes.

14.2 Laboratory Report

Your reports should consist of the following parts:

1. A cover page giving the date the experiment was performed, the name of your laboratory partner and the title of the experiment;
2. Your procedure signed by your TA;
3. A description of how you solved the riddle at the beginning of the experiment. Be sure to include a description of the physical principals used to solve the riddle. These principals, of course, should relate to the rest of the experiment.
4. The raw data [in this case the original graph paper screen signed by your TA];
5. A table of 10 values of X' and $\Delta X'$ calculated from the graph paper for each time;
6. Graphs of $\Delta X'$ as a function of X' for each time;
7. A statement of the precise definition you used for the width w of each graph;
8. A table of w , t , $\ln w$ and $\ln t$;

9. Plot the values of $\ln w$ as a function of $\ln t$ using the calculated points;
10. Draw a straight line that is your best estimate of the linear relationship between $\ln w$ and $\ln t$;
11. Determine the slope of your graph;
12. Given that the slope is either an integer or a half integer, round off the value of your slope to the nearest half integer;
13. Express the dependence of the the width as a power law. It is important to recognize that the width w is proportional to the standard deviation σ of the Gaussian curves.
14. Summary and Discussion: Briefly summarize the experiment and your findings. Include all key numerical results; e.g. power law. Examine Eq. (17.18) of the CHM 431 textbook, and compare your measured value of α with the power law of the mean squared displacement in diffusion processes as a function of time.

15 Notes on Error Analysis

15.1 Reading Assignment

Text pages 3-6, 17-22, 26-41.

15.2 Introduction

The study of the analysis of experimental error is an important goal of CHM 335. The instructors of this course feel error analysis to be sufficiently important that from 30% to 40% of the grade on your later laboratory reports are based on this topic. We encourage you to learn this topic well as early in the semester as possible. Many aspects of error analysis are complex, and the lecture together with these course notes and the appropriate sections of the text book should be helpful. In preparing your reports we encourage you to come to the instructors for help with error analysis to make sure you understand the key ideas.

To illustrate the importance of the analysis of errors, suppose a surveyor measures the distance between Kingston and New York City, and reports the distance to be 150. miles. While stating the distance to be 150 miles might be sufficient for the Auto Club, from the point of view of the physical sciences the reported distance alone is inadequate. For example, the surveyor might mean 150 miles \pm 1 mile or the surveyor might mean 150 miles \pm 100 miles. The first possibility tells us that it should take about 3 hours to drive to New York while the latter is only a rough order of magnitude estimate. While the auto club probably assumes something like 150 miles \pm 1 mile, anyone in the sciences must provide not only the result of a measurement, but the extent to which the result is known as well. Starting with the third experiment when you report an experimental result, you must include both

the value obtained as well as the error that provides information about how well you know the result reported.

15.3 Systematic and Random Errors

Experimental errors are often divided into two categories. The first category, usually called *systematic errors*, refers to mistakes inherent in a particular apparatus. For example, suppose we measure the length of the cover of your textbook with a metal ruler. The total length of the ruler expands and contracts depending on the temperature of the room. The ruler might be calibrated assuming the temperature is 20°C, and if the actual room temperature is 25°C, the total length of the ruler must be longer than originally measured. Consequently, any measurement of length at the higher temperature can be expected to give a result that is too short. It is important to recognize that systematic errors have a definite algebraic sign. In the case of our expanded ruler, the error is necessarily negative. There is some control over such systematic errors. For example, if the coefficient of thermal expansion of the ruler is known, the measured length can be corrected to provide the true length. Associated with systematic errors is the term *accuracy*. An apparatus is said to be accurate to the extent that the systematic errors are minimized.

The second category of error is associated with inherent random fluctuations of any measurement apparatus, and consequently we refer to such errors as *random errors*. Again, we can take the measurement of the length of the cover of our textbook as an example. If we measure the length of the book many times, we can expect to obtain a range of values that fluctuates about a mean value. The fluctuations come from many sources. For example, you might not place the bottom of the ruler at exactly the same place for each measurement. The thermal fluctuations of the atoms in the ruler change its length slightly providing another source. The temperature of the room also fluctuates changing the length of the ruler in a random way. Such random fluctuations are inherent, and cannot be eliminated. By hypothesis, we assume the correct result (in the sense of random errors) for some measurement can be obtained from the arithmetic mean of an infinite set of measurements. We control random errors by increasing the number of measurements. Unlike systematic errors, random errors have no definite algebraic sign, and we denote the size of random errors with \pm notation. We use the term *precision* to express the magnitude of the random errors. We call a measurement precise if its random errors are small.

15.4 The Distribution of Random Errors - The Gaussian Distribution

An important theorem in probability theory, called *the central limit theorem*, states that random, independent measurements of a quantity (call it x) must be distributed according to a *Gaussian* distribution that takes the form

$$P(x) = \frac{1}{\sqrt{2\pi\sigma^2}} \exp \left\{ -\frac{(x - \mu)^2}{2\sigma^2} \right\}. \quad (4)$$

Figure 6

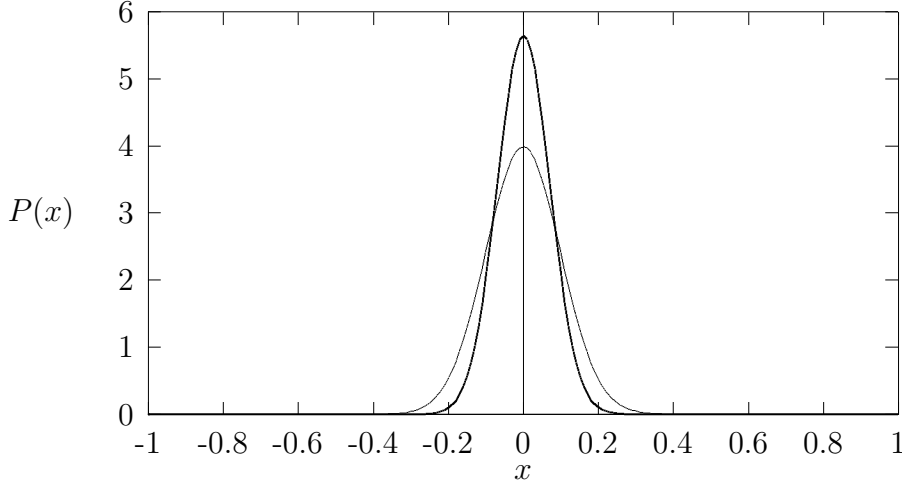

The meaning of the parameters σ and μ are given shortly. Equation (4) is plotted in Figure 6 for the case that $\mu = 0$ and $\sigma = 1$. (the broader peak) and $\mu = 0, \sigma = 0.5$ (the narrower peak). The probability function $P(x)$ is normalized in the sense that

$$\int_{-\infty}^{\infty} dx P(x) = 1 \quad (5)$$

implying that $P(x)$ is a well-defined probability function. The average of x is given by

$$\langle x \rangle = \int_{-\infty}^{\infty} dx x P(x) = \mu \quad (6)$$

so that the point $x = \mu$ locates the peak of $P(x)$ and, by symmetry, is also the mean. A second important integral is

$$\langle x^2 \rangle - \langle x \rangle^2 = \int_{-\infty}^{\infty} dx x^2 P(x) - \mu^2 = \sigma^2. \quad (7)$$

The parameter σ is often called the *standard deviation* and is a measure of the width of the distribution. It is possible to show that

$$\int_{-\sigma}^{\sigma} dx P(x) \cong 0.66 \quad (8)$$

and

$$\int_{-2\sigma}^{2\sigma} dx P(x) \cong 0.95. \quad (9)$$

Because $P(x)$ represents the distribution of measured values about the mean μ , Eqs. (8) and (9) imply that the result of any measurement has a 66% chance of occurring in the range $\mu \pm \sigma$ and a 95% chance of occurring in the range $\mu \pm 2\sigma$.

15.5 Calculation of Random Errors for a Finite Set of Laboratory Measurements

The distribution $P(x)$ is exact only for an infinite set of independent measurements. Naturally, in a laboratory we can only generate a finite set of measured data. For a finite set of measurements presumably distributed according to $P(x)$, we estimate μ and σ . To estimate σ and μ for a finite set of measurements, we imagine the set of N measured values to be x_1, x_2, \dots, x_N . The mean is given by the standard expression

$$\mu = \frac{x_1 + x_2 + \dots + x_N}{N} = \frac{1}{N} \sum_{i=1}^N x_i. \quad (10)$$

To determine the standard deviation we use

$$\langle x^2 \rangle = \frac{1}{N} \sum_{i=1}^N x_i^2, \quad (11)$$

so that

$$\sigma^2 = \frac{1}{N} \sum_{i=1}^N x_i^2 - \left(\frac{1}{N} \sum_{i=1}^N x_i \right)^2. \quad (12)$$

The standard deviation σ represents a measure of the fluctuations of x from a large set of measurements. Although σ is of interest, our principle concern is the fluctuations of the calculated mean. It is not hard to show that the standard deviation of the mean itself σ_N is given by

$$\sigma_N^2 = \frac{\sigma^2}{N-1} \quad (13)$$

(the $N-1$ rather than N comes from the loss of one degree of freedom in the estimation of the mean). We then report our results in the form

$$x = \mu \pm 2\sigma_N. \quad (14)$$

From the discussion at the end of Section 15.4, there is a 95% probability that the correct result is in the range given in Eq.(14).

Exercise: A student measures the mass of an iron nail with a balance and obtains the following results: 5.500 g, 5.560g, 5.550g, 5.550g and 5.590g. Calculate the result that the student should report.

Answer: The average mass is found to be 5.550 grams, $\sigma = .02898$ grams, and $\sigma_N = .01449$ grams. The reported result should be $5.55 \pm .03$ grams. Notice the first significant digit in the error defines the number of significant figures that should be reported for the average. We don't use simple first year chemistry rules for significant figures, but rather we use the computed error to define the number of significant figures to be reported.

The answer to the previous exercise requires rounding off to the last significant digit. The usual rule for rounding off digits is to increase by one digit if the next digit is greater than 5, do not increase by one digit if the next digit is less than 5, and increase by one digit if the next digit is 5 and the result of the round off is even. For example 5.56 becomes 5.6, 5.54 becomes 5.5 and 5.55 becomes 5.6. However 5.65 becomes 5.6.

In most cases it is important to repeat a measurement about 10 times to ensure the generation of proper statistics so that the magnitude of the random errors can be estimated. With the exception of the third experiment, in CHM 335 there is not adequate time to perform 10 measurements. Consequently, the size of the random errors for a particular measurement is estimated. As a rule of thumb the size of the random error for a measurement is ± 2 in the last reported digit(we assume the ± 2 error to be at the 95% confidence level; i.e. 2 standard deviations of the mean). For example, when using the analytical balances, it is possible to read the mass to four decimal places. If a particular sample has a measured mass of 4.2345 grams, it is safe to assume the mass to be $4.2345 \pm .0002$ grams. In the case of volumetric flasks, the size of the random error is printed on the flask below the label of the total volume of the flask. When using a volumetric flask, it is important to record the error in the flask volume when recording your data. For volumetric pipettes (so called class A glassware), the random errors are those given in the following table:

Volume (ml)	random error (ml)
1.	0.01
2.	0.01
5.	0.02
10.	0.02
20.	0.03
25.	0.03
50.	0.04
100.	0.06

15.6 Error Propagation

1. Treatment of Systematic Errors

Perhaps the most difficult topic in error analysis is how errors in basic measurements propagate to a final result. For example the pH of a solution is defined by

$$pH = -\log_{10}[H^+] = -\ln[H^+]/2.3 \quad (15)$$

(really, the definition of the pH is in terms of activities of the hydrogen ion, but we can take it to be defined in terms of concentrations for our purposes). If the hydrogen ion concentration is measured directly with a known statistical error, we now discuss how to determine the error in the pH . The generic form of this problem can be discussed in terms of a function $f(x, y, z, \dots)$ where x, y, z, \dots represent fundamental quantities

measured directly, and f represents the actual physical quantity to be reported. In our pH example, there is a single fundamental measured quantity $x = [\text{H}^+]$, and the function is $f(x) = -(1/2.3) \ln x$.

The total differential of a function provides the mathematics necessary to solve the problem of error propagation. The total differential plays a central role in the study of thermodynamics as well, and total differentials are discussed in detail in CHM 431. As a reminder, the total differential of a function f is defined by

$$df = \left(\frac{\partial f}{\partial x}\right)_{y,z,\dots} dx + \left(\frac{\partial f}{\partial y}\right)_{x,z,\dots} dy + \left(\frac{\partial f}{\partial z}\right)_{x,y,\dots} dz + \dots \quad (16)$$

The total differential of f is the infinitesimal change in f that results from the infinitesimal changes in its variables expressed as dx, dy, dz, \dots . In the case of errors, df is the error in f that arises from small errors dx, dy, dz, \dots in each of its variables. The interpretation of df just provided in terms of errors is valid for systematic errors. We shall discuss the modifications for random errors in Section 2. We first try the application of the total differential to our pH example. Using $f = pH$ and $x = [\text{H}^+]$ we have

$$f = -\left(\frac{1}{2.3}\right) \ln x \quad (17)$$

and

$$df = -\frac{dx}{2.3 x}. \quad (18)$$

Then

$$\epsilon(pH) = -\frac{\epsilon([\text{H}^+])}{2.3[\text{H}^+]} \quad (19)$$

where the notation $\epsilon(x)$ denotes the systematic error in the variable x . The error in the pH is not simply equal to the error in the hydrogen ion concentration itself, but rather the error in the pH is a function of the error in the hydrogen ion concentration as well as other variables. The functional form of the expression for the error cannot be guessed in any simple way, but must be derived from the expression for the total differential. Because systematic errors have a definite algebraic sign, the systematic error in the pH carries sign information.

Let us try another example. The density ρ of a substance is defined by

$$\rho = \frac{m}{V} \quad (20)$$

where m is the mass and V is the volume. For the purpose of this exercise we take the mass and the volume as the quantities actually measured in a laboratory, and we ask how the errors in the mass and volume propagate to give the final error in the density. Writing $\rho = \rho(m, V)$ The total differential of the density is given by

$$d\rho = \left(\frac{\partial \rho}{\partial m}\right)_V dm + \left(\frac{\partial \rho}{\partial V}\right)_m dV \quad (21)$$

$$= \frac{dm}{V} - \frac{m dV}{V^2}. \quad (22)$$

The expression for the total differential in the density can be simplified by dividing the left hand side of Eq.(22) by ρ and the right hand side of Eq.(22) by m/V resulting in the expression

$$\frac{d\rho}{\rho} = \frac{dm}{m} - \frac{dV}{V}. \quad (23)$$

The expression for the propagation of systematic errors then takes the form

$$\frac{\epsilon(\rho)}{\rho} = \frac{\epsilon(m)}{m} - \frac{\epsilon(V)}{V}. \quad (24)$$

The right hand side of Eq.(24) contains sign information. A positive systematic error in the mass results in a positive error in the density whereas a positive systematic error in the volume results in a negative systematic error in the density. These signs make sense, because increasing the volume decreases the density (the volume term appears in the denominator).

In this course we generally assume that there are no systematic errors. We have included the analysis of this section to provide the needed mathematics for the treatment of random errors. In your laboratory reports you should focus on random errors, the method for which is discussed in the next section.

2. Treatment of Random Errors

In the previous section the expressions for the propagated systematic errors contained sign information. Unlike systematic errors, random errors contain no signs. It is possible to show that the expressions for systematic errors become valid for random errors if each term in the expression derived from the total differential is squared and averaged so that cross terms are eliminated. The proof of this assertion is beyond the scope of this course. To make the procedure explicit, consider a function f of two measured quantities x and y . The total differential of f is given by

$$df = \left(\frac{\partial f}{\partial x} \right)_y dx + \left(\frac{\partial f}{\partial y} \right)_x dy. \quad (25)$$

As before, we replace the differentials by errors

$$\epsilon(f) = \left(\frac{\partial f}{\partial x} \right)_y \epsilon(x) + \left(\frac{\partial f}{\partial y} \right)_x \epsilon(y). \quad (26)$$

Equation(26) is just the expression valid for the propagation of a systematic error. We now square both sides of Eq.(26) and average. By averaging, the cross terms containing

terms of the form $\epsilon(x)\epsilon(y)$ average to zero because each individual error can have both positive and negative signs. The final result for the propagated random error is then

$$\epsilon(f)^2 = \left(\frac{\partial f}{\partial x}\right)_y^2 \epsilon(x)^2 + \left(\frac{\partial f}{\partial y}\right)_x^2 \epsilon(y)^2. \quad (27)$$

(We have replaced the symbol ϵ that represents a systematic error by the symbol ϵ to represent a random error.) To apply the procedure to our density example, we can begin with Eq.(24), square both sides and average to obtain

$$\left(\frac{\epsilon(\rho)}{\rho}\right)^2 = \left(\frac{\epsilon(m)}{m}\right)^2 + \left(\frac{\epsilon(V)}{V}\right)^2. \quad (28)$$

Note: Students often mistakenly double a propagated error imagining that the propagated error must be at the single standard deviation (66 %) confidence level. In fact, the error in the fundamental measured quantities should already be expressed as 2 standard deviations of the mean, and the propagated error represents 2 standard deviations of the mean. No doubling of the propagated error is necessary.

Exercise: An expression for the vapor pressure of a certain liquid from a particular experiment takes the form

$$\ln(p_2 - p_1) = \frac{\lambda}{RT}$$

where p_1 and p_2 are two measured pressures expressed in unitless form, R is the gas constant ($8.3144 \text{ J mol}^{-1}\text{K}^{-1}$), λ is the enthalpy of vaporization, and T is the temperature in degrees Kelvin. Suppose the experiment is used to determine the value of λ , and the measured data are $p_2 = 5.53 \pm 0.02$, $p_1 = 4.07 \pm 0.09$, and $T = 275.1 \pm 0.1\text{K}$. Use the data to determine λ , determine the propagated error in λ and express the result with the appropriate number of significant figures. For simplicity, you should assume R is an exact constant with no associated error (in fact R is an experimental number with associated but small random errors).

Answer:

$$\epsilon(\lambda) = \sqrt{(R \ln(p_2 - p_1))^2 \epsilon^2(T) + \left(\frac{RT}{p_2 - p_1}\right)^2 \epsilon^2(p_1) + \left(\frac{RT}{p_2 - p_1}\right)^2 \epsilon^2(p_2)}$$

$$\lambda = (9. \pm 1.) \times 10^2 \text{ J mol}^{-1}$$

3. Special Useful Expressions for the Propagated Error

In general to determine the expression for a propagated error, the direct calculation of the total differential is necessary. The previous exercise illustrates the need to actually determine the total differential. However, there are two special cases that are so common that it is useful to derive general expressions for future use. The first is a function that depends *only* on the sums and differences of its variables. For example $f(x, y, z) = x + y - z$. The total differential of f is

$$df = dx + dy - dz. \quad (29)$$

After replacing the differentials by errors and squaring and averaging, the result is

$$\varepsilon(f) = \sqrt{\varepsilon(x)^2 + \varepsilon(y)^2 + \varepsilon(z)^2}. \quad (30)$$

In general the propagated random error for any function of only the sums and differences of its variables is the square root of the sums of the squares of the errors in its variables.

The second important case is a generalization of our density example. Suppose f is a function *only* of products and quotients of its variables. For example take $f = xy/z$. The total differential of f is

$$df = \frac{y}{z}dx + \frac{x}{z}dy - \frac{xy}{z^2}dz. \quad (31)$$

Dividing the left hand side of Eq.(31) by f and the right hand side of Eq.(31) by xy/z , we obtain

$$\frac{df}{f} = \frac{dx}{x} + \frac{dy}{y} - \frac{dz}{z}. \quad (32)$$

We next replace the differentials by errors and square and average to obtain

$$\varepsilon(f) = f \sqrt{\left(\frac{\varepsilon(x)}{x}\right)^2 + \left(\frac{\varepsilon(y)}{y}\right)^2 + \left(\frac{\varepsilon(z)}{z}\right)^2}. \quad (33)$$

We can interpret Eq.(33) by stating the relative error in f is the square root of the sum of the squares of the relative errors in each of its variables. This result can be extended to any number of variables as long as all variables appear as products or quotients only.

15.7 Errors from a Graphical Analysis of the Data

Frequently the physical result we seek in an experiment is extracted from the slope or the intercept of a linear graph obtained from a series of data. For example, suppose the goal of an experiment is to determine a value of the gas constant R from pVT data obtained from

Figure 7 – A graph of pV as a function of T

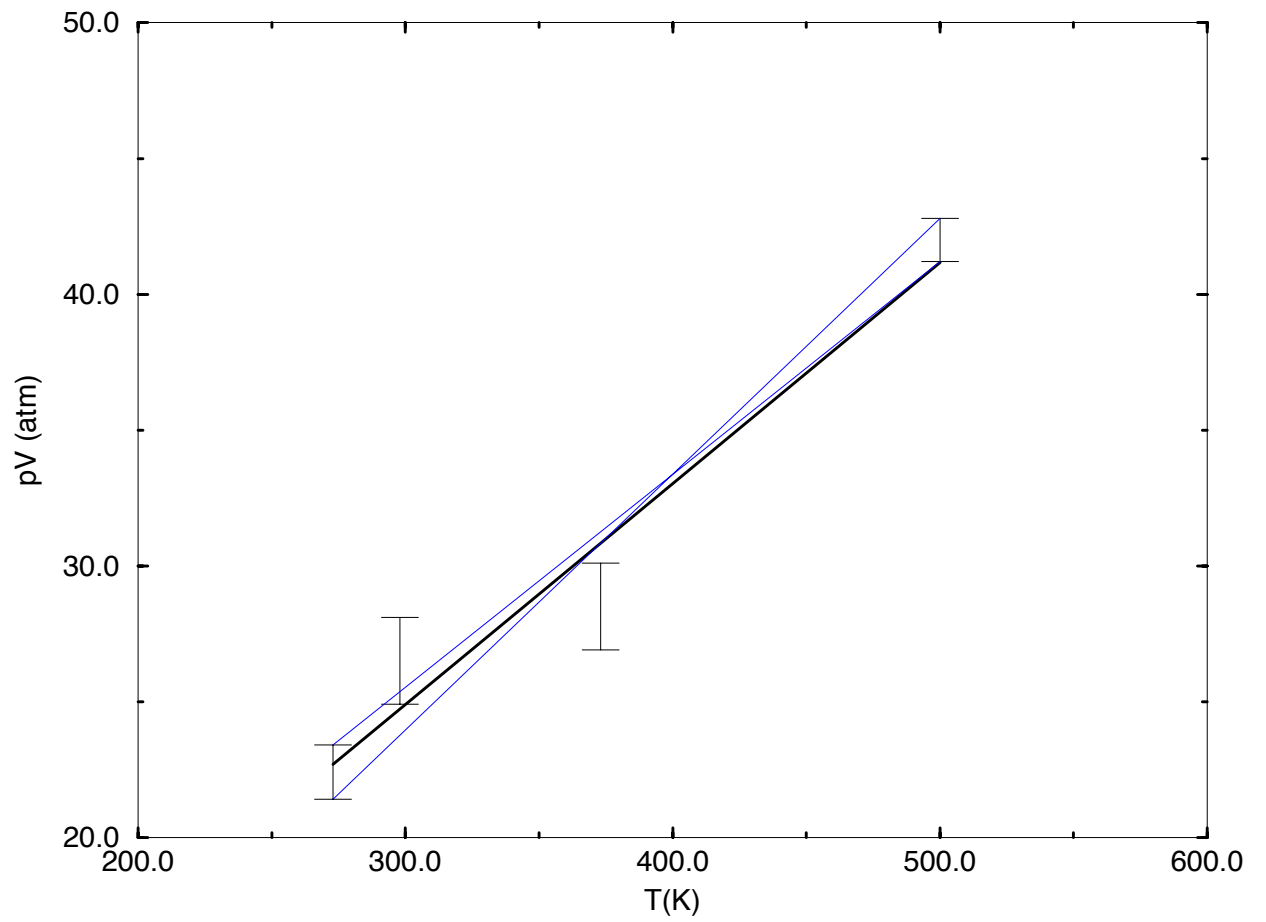

measurements using one mole of an ideal gas. The value of R can be obtained from the slope of a graph of the product pV plotted as a function of the temperature T . An example of such data is shown in Figure 7. In the data shown in Figure 7, the random errors in the temperature are smaller than the resolution of the graph. The random errors in the pV product are large and depicted by the vertical bar with the horizontal lines at the head and foot associated with each data point. For example the first plotted point in Figure 7 is 22.4 ± 1 l atm. A point is plotted at $pV = 22.1$ l atm and the vertical bar ranges from 21.1 l atm to 23.1 l atm. These vertical bars are called *error bars*. When plotting points containing random errors, associated with each point must be an error bar. There should be error bars parallel to both the x and y -axes, but in this example (and most of the experiments in this course), the error bars for the data plotted on the x -axis are too small to see.

Perhaps the best way to determine the optimal line that connects a set of experimental points is called *linear regression*. Linear regression is discussed in your textbooks, but in CHM 335 we use a simpler method. We draw the best straight line using a visual fit. The best straight line drawn in this way is depicted as the darkest solid line in Figure 7. From this best fit line, the slope can be determined. The slope so determined is taken to be the slope to be reported in your laboratory experiment. For example, the slope of the best-fit (dark) line in Figure 7 is 0.0814 l atm K^{-1} . We ask that you analyze your data in this way using graph paper rather than a computer. In the final experiment of the year, the reports are written in class, and by preparing your graphs using graph paper rather than a computer, you have the necessary practice for the final laboratory project.

To obtain an estimate of the errors associated with the slope of a graph (or equivalently the intercept), the plotted error bars are used to obtain extreme values of the possible slope and intercept. In this course we take the first and last plotted points, and connect the bottom of the first error bar to the top of the last error bar with a straight line. Similarly, we connect the top of the first error bar with the bottom of the last error bar with another straight line. These two lines are depicted in Figure 7 as the two light solid lines. We call the slope of the light solid line having the largest slope m_+ and the slope of the light solid line having the smallest slope m_- . We estimate the error in the slope to be

$$\varepsilon(m) = \frac{1}{2}(m_+ - m_-) \quad (34)$$

For example, in Figure 7 $m_+ = 0.0942$ l atm K^{-1} , $m_- = 0.0784$ l atm K^{-1} so that the error is $\varepsilon(m) = 0.008$ l atm K^{-1} . We then report the gas constant to be $R = 0.0814 \pm 0.008$ l atm $\text{mol}^{-1} K^{-1}$. The error estimated in this fashion can often be an over estimate. Consequently we can take the error calculated in Eq.(34) to represent two standard deviations of the mean; i.e. at the 95% confidence level.

Although linear regression is capable of providing a more careful estimate of the error in the slope from a set of data, the method expressed in Eq.(34) is more suitable for the purposes of CHM 335.

The error in the intercept b is treated analogously.

$$\varepsilon(b) = \frac{1}{2}(b_+ - b_-) \quad (35)$$

16 Experiment 9(28)a: The Intrinsic Viscosity of Polyvinyl Alcohol

16.1 Introduction and Reading Assignments

In this and the next experiment, you use the measurement of the the viscosity of liquids to illustrate two things. In the first experiment you learn the methods of error analysis. In the experiment to be performed in the following week, you use viscosity measurements to discover certain aspects of polymer structure. In the second part you learn the format of a complete laboratory report as well. Before coming to the laboratory, be sure to read pages 106 to 115 in your text book as well as pages 3-41 in your text. The latter reading assignment presents a discussion of error analysis.

16.2 Theory

When one of the instructors for this course was young (we won't tell you how long ago) there was a TV commercial for Prell Shampoo. To show how "wonderful" Prell was, the advertisement showed two beakers, one filled with Prell and the other filled with water. A pearl was placed at the top of each solution and the rate at which the pearl reached the bottom of the beakers was demonstrated. The pearl took much longer to reach the bottom in the beaker containing Prell than in the beaker containing water.

The difference in rate (which for some reason was supposed to show how good Prell is) is a measure of what we call *viscosity*. Another way of observing the effect of differing viscosity is to pass solutions through a pipe or a narrow capillary. The more viscous the solution the longer it will take for the liquid to pass through the tube. This difference in flow rate is the basic principle behind the Ostwald viscometer that we shall use in this experiment.

The physical origin of viscosity can be understood by imagining two trains of infinite length running on parallel frictionless tracks. Suppose the train on the right track is moving at a higher speed than the train on the left track. Suppose the doors of the trains are open and the passengers on each train participate in a game where they hop back and forth between the two trains at some rate. The passengers jump so that on average the number of people on either train is constant. A person jumping from the fast train to the slow train transfers momentum from the fast train to the slow train. A person jumping from the slow train to the fast train transfers negative momentum. This process of momentum transfer tends to slow the fast train and speed up the slow train. To an observer too far from the train to see the jumping, the change in speed appears to be a frictional drag between the two trains.

Now consider a liquid flowing down a pipe. Imagine the fluid flowing down the pipe to consist of concentric cylindrical layers of decreasing diameter starting at the wall of the pipe and ending at the axis of the pipe. It turns out that the layer adjacent to the wall of the pipe has zero speed and the speed increases from the wall to a maximum at the center of the pipe. Each layer is analogous to the trains described in the preceding paragraph and the

molecules that jump between the layers (because of Brownian motion) are analogous to the people jumping between the trains. When we measure the properties of the fluid as it flows down the pipe, we observe a frictional drag between the layers. This frictional drag is the viscosity.

The detailed theoretical background for the experiments is given in the reading assignments. It is useful to note that the key equation for the experiment is given as Eq. (3) in the laboratory text

$$\frac{\eta}{\rho} = Bt \quad (36)$$

where η is the viscosity, ρ is the solution density, B is a constant of proportionality and t is the time necessary for a solution to pass through an Ostwald viscometer.

16.3 Experimental Procedure

In this first experiment you limit the measurements to determine the viscosity of the single solution of polyvinyl alcohol by comparison with the viscosity of water. Set up the experimental apparatus as in Figure 1 on page 320 of your text books. Measure the time it takes for water to pass between the marks of the viscometer. You should repeat the measurements for water 10 times. Then perform 10 measurements of the flow time for the polyvinyl alcohol stock solution. Clean the Ostwald viscosimeter thoroughly with 3 portions of distilled water after your polyvinyl alcohol runs. Use a rubber bulb to force water through the capillary tube several times to remove polyvinyl alcohol from the capillary. After the cleaning, repeat the viscosity measurement of distilled water twice. Record the water run time in your data sheet before you ask your TA to sign your data sheet. Fill the Ostwald viscosimeter with distilled water at the end of the laboratory period.

16.4 Laboratory Report

In your report you have only three sections; a calculations section, an error analysis section, and a section summarizing your results. Tables of the density and viscosity of water needed for your laboratory reports are found on the last page of this syllabus.

1. Include a cover page giving the title of the experiment and the date the experiment was performed.
2. Include the signed outline of the experimental procedure.
3. Calculations
 - (a) Make a table consisting of the ten values of the flow time for the water measurements and the polyvinyl alcohol solution measurements.
 - (b) Calculate the average flow time for each species.

- (c) Determine the density and viscosity of water using the tables at the end of this syllabus. As an example, the density of water at 23.1C is $0.997514 \text{ g cm}^{-3}$. The viscosity of water at 23.C is 9.38 mP.
 - (d) Use the mean value for water and the known viscosity of water to determine the apparatus constant B .
 - (e) Using the determined value of B , calculate the viscosity of the polyvinyl alcohol solution.
4. Error Analysis
- (a) Calculate the standard deviation of the mean of the flow time for water.
 - (b) Calculate the standard deviation of the mean of the flow time for the polyvinyl alcohol solution.
 - (c) Propagate errors to determine the error in B .
 - (d) Propagate errors to determine the error in the viscosity of the polyvinyl alcohol solution.
5. Summarize your measured results including the calculated errors. Be sure to include the proper number of significant figures and the proper units.
6. Remember to attach your original data signed by your TA.

Because you need additional experience in error propagation before attempting the next laboratory experiment, do the following exercises as the final section of your laboratory reports:

1. A student has a sodium chloride solution having concentration 1.03 ± 0.02 molar. 50.0 ± 0.1 ml of the solution are placed in a volumetric flask of volume 100.0 ± 0.2 ml, and the solution is mixed with water to the mark on the flask. Determine the final concentration along with its associated random error.
2. The final solution from problem 1 is again diluted in half with water using a pipette and volumetric flask with the same specifications. Determine this final concentration with the associated random error.
3. Later in the semester, you will determine a quantity γ using pressure measurements having the form

$$\gamma = \frac{\frac{P_2}{P_1} - 1}{\frac{P_3}{P_1} - 1}.$$

Suppose the measured pressures are $P_1 = 32.0 \pm 0.2$ torr, $P_2 = 43.2 \pm 0.3$ torr and $P_3 = 762. \pm 1$ torr. Calculate γ and the associated random error. Be careful. In this problem, taking the total differential is essential.

4. In the same experiment later this semester, you will determine a related expression for γ given by

$$\gamma = \frac{\ln \frac{P_2}{P_1}}{\ln \frac{P_3}{P_1}}.$$

Using the same data as in the previous problem, determine γ and the associated random error.

17 Experiment 9(28)b: The Intrinsic Viscosity of Polyvinyl Alcohol

17.1 Introduction

In this follow-up experiment, you use the viscosity measurements to determine the fraction of polymer units that are connected in the so-called “head to head” arrangement. The approach is to use a reagent that cleaves the head to head connections exclusively. The cleavage increases the number of molecules in solution and decreases the average molecular weight. This change is related to the viscosity. The experimental procedure that you use is identical to that given in the text book. The next subsection will contain a discussion of some of the theoretical ideas.

17.2 Theory

We define Δ to be the fraction of bonds connecting monomer units in a strand of polyvinyl alcohol that are connected “head to head.” Let W be the total mass of polyvinyl alcohol in the solution. The total number of monomer units, N_0 , is equal to W divided by M_0 where M_0 is the molecular weight of a monomer; i.e.

$$N_0 = W/M_0 \quad (37)$$

Let N_n be the total number of polymer molecules in the solution before cleavage and N'_n be the total number of polymer molecules in solution after cleavage. If M_n is the molecular weight of the polymer and M'_n is the polymer molecular weight after cleavage, then

$$N_n = W/M_n \quad (38)$$

and

$$N'_n = W/M'_n. \quad (39)$$

Assuming the molecular weights of the polymers are high, to a vanishingly small error we can then write

$$\Delta = \frac{N'_n - N_n}{N_0} \quad (40)$$

$$= \frac{1/M'_n - 1/M_n}{1/M_0} \quad (41)$$

We can then determine Δ from a knowledge of the molecular weights.

We determine the molecular weights using changes in the viscosity that accompany the cleavage process. In a polymer the viscosity increases with increasing molecular weight. The principal reason is that the average volume of the polymer molecules in solution increases with chain length. The quantitative dependence on the molecular weight can be understood by viewing the polymer in a spherical model as discussed in the text book. The final result is found in Eq. (7) on page 323. Since the solution consists of a statistical ensemble, the molecular weights used are averages resulting in additional correction factors as given in Eq. (11) on page 324 of the text.

Please note that the second of the two equations listed as Eq. (7) on page 323 of the text is in error. You should use

$$M = 7.4 \times 10^4 [\eta]^{1.32}.$$

17.3 Cleaning Procedure

As with the first part of this experiment, clean the Ostwald viscosimeter thoroughly with 3 portions of distilled water after your polyvinyl alcohol runs. Use a rubber bulb to force water through the capillary tube several times to remove polyvinyl alcohol from the capillary. After the cleaning, repeat the viscosity measurement of distilled water twice. Record the water run time in your data sheet before you ask your TA to sign your data sheet. Fill the Ostwald viscosimeter with distilled water at the end of the laboratory period.

17.4 Laboratory Report

You write complete laboratory reports for this experiment. Before writing your reports, be sure to read pages 10 to 25 in your text books. Your reports should contain the following sections:

1. Title Page: Give the title of the experiment and the date the experiment was performed.
2. Abstract: This should be a 1 paragraph summary of what is to follow including the results. It is suggested that you write the abstract after the rest of the report is complete.
3. Introduction: This should be a discussion of the purpose of the experiment.
4. Theory: This should provide a derivation of the key formulas used in the experiment and used in the analysis of the data. Make sure that all symbols used in this section are defined in words.
5. Procedure: Attach the outline of the procedure you brought to class and had signed by your TA.

6. Original Data: Attach the original data signed by your TA.
7. Results: Tabulate your data so that it can be used in the calculations to follow.
8. Calculations: Provide a sample calculation taking one from the original data to the final result.
9. Error Analysis: Use the standard deviations computed in last weeks experiment as an estimate of the error in the flow times. Determine the error in the specific viscosity by propagation.
10. Graphical Analysis: Plot the specific viscosity divided by the concentration as a function of concentration. Draw the best line through the data. Include error bars on the data points. Use the limiting slope method to determine the intercept and the error in the intercept.
11. Final Calculation: Determine the best average molecular weights for both the cleaved and uncleaved samples. Then calculate Δ . It is possible to determine the error in Δ and the average molecular weight by error propagation. However, we do not expect you do determine these errors in this laboratory report.
12. Summary of Data: Summarize the final results. In particular include the average intrinsic viscosity, the average molecular weight and the best estimate of Δ . Be sure to include the errors for the intrinsic viscosity when reporting your final results, and be sure to report only the proper number of significant figures.
13. Conclusions: Discuss the significance of your results. Be sure to discuss the frequency of the head to head connections and discuss the principal sources of error. Make suggestions for how the experiment might be improved.

18 Format of Laboratory Reports for Remaining Experiments

The laboratory reports for the remaining experiments should all have the same format. Each report should have the following sections:

1. Title Page: Give the title of the experiment, the date the experiment was performed and the name of your laboratory partner (if any).
2. Abstract: This should be a 1 paragraph summary of what is to follow including the results. It is suggested that you write the abstract after the rest of the report is complete.
3. Introduction: This should be a discussion of the purpose of the experiment.

4. Theory: This should provide a derivation of the key formulas used in the experiment and in the analysis of the data. Definitions must be provided for all symbols used in this and subsequent sections.
5. Procedure: Attach the outline of the procedure you brought to class and had signed by your TA.
6. Original Data: Attach the original data signed by your TA.
7. Data Table: Tabulate your data so that it can be used in the calculations to follow.
8. Calculations: Provide a sample calculation taking one from the original data to the final results.
9. Graphical Analysis: If required, plot your data on a graph. Draw the best line through the data. Determine the slope and/or intercept of the graph as needed.
10. Error Analysis: Perform any necessary propagation of errors. You need show only one example of any one kind of propagation.
11. If a graph is needed use the calculated errors to include error bars on the graph. Use the limiting slope method to determine the error in the slope and/or intercept.
12. Propagate the errors from the graph to give the errors in the final results.
13. Summary of Data: Summarize the final result with error bars included. Be sure to report only the proper number of significant figures.
14. Conclusions: Discuss the significance of your results. Make suggestions for how the experiment might be improved.

19 Experiment 7(13) - The Vapor Pressure of a Pure Liquid

19.1 Reading Assignment

Read experiment number 7(13), pages 85-93 in the text.

19.2 Experimental Notes

1. The boiling point method is used. Follow the procedure in the book.
2. Our experimental design uses an open ended electronic manometer. Readings from an open ended manometer gives the pressure relative to the atmospheric pressure. The atmospheric pressure must be obtained by reading the electronic barometer.

3. No baffle is used.
4. We use the internal vacuum line (colored orange in our building) for the vacuum pump.
5. Glassware under vacuum is dangerous if broken. Avoid tampering with the connections when the system is evacuated. **Wear goggles at all times. The evacuated glassware can implode!**
6. Fill the boiling flask about 1/3 full with distilled water and fresh boiling chips. This will be used for the entire experiment.
7. When the thermometer is correctly positioned, the bottom of the bulb is even with the top of the boiling flask.
8. The condenser must be run during the experiment.
9. With the water aspirator, evacuate the system until the lowest pressure is reached (~60-80 torr). Then, close the stopcock on the trap.
10. Check for leaks by observing the manometer for 5 minutes after reaching the lowest pressure and closing the system. The system is leaking if the pressure changes by more than 1 or 2 torr in the five minute period. If the system is leaking, increase the pressure by opening the stopcock in the connection between the ballast and the trap. Then check all joints. The joints should be clean, greased and tight. Recheck the system for leaks by evacuating the system to lowest pressure again.
11. When the system is free of leaks, begin the heating process. Set the variastat at ~60-80 and heat rapidly until boiling. Then lower the variastat to ~30 to attain a gentle but steady boil.
12. Begin with the ascending cycle first. Take 10 readings spaced approximately as shown in the book. Then descend taking another 10 readings. Repeat this process one additional time. The aspirator should be off during the ascending cycle.
13. At each pressure allow the system to equilibrate. Take pressure/temperature readings simultaneously every 30 seconds. When three readings in a row are the same, the system has reached equilibrium.
14. After the completion of the experiment, release the vacuum, shut off the water to the condenser, empty the trap and wash the boiling flask. Do not put boiling chips in the drain. Dispose of the boiling chips in the trash.

19.3 Laboratory Report

1. Error Analysis:
 - (a) Estimate the error bars for only the first and last points of the graph used to determine the enthalpy of vaporization.
 - (b) Estimate the error in the slope using the limiting slope method.
 - (c) Estimate the error in Z by visual inspection of Figure 1 in the textbook.
 - (d) Propagate the errors to obtain an error in ΔH_v .
2. Conclusions: Compare your result with literature values. Use your experimentally derived enthalpy of vaporization to calculate the entropy of vaporization. Compare your result with Trouton's Rule [Engel and Reid, p. 194] and explain the differences.

20 Experiment 6(11) - Freezing-point Depression of Strong and Weak Electrolytes

20.1 Reading Assignment

Experiment 11, Pages 79-84(188-193,) Text.

20.2 Experimental Notes

1. We will only perform measurements on chloroacetic acid. The part of this experiment on hydrochloric acid can be ignored.
2. Follow the textbook instructions using the order of tasks given here.
3. Make sure that the stock solutions and a container of deionized water are in ice baths. If not, talk to your TA.
4. We will use a digital thermometer precise to ± 0.01 C.
5. Add about 300 mL of deionized water to the Dewar along with about 100 mL of ice. It is important that the level of liquid in the Dewar cover the bottom third of the thermometer. Let the ice water stand for 5 minutes.
6. Use an analytical balance to determine the mass of the clean and dry weighing bottle.
7. Vigorously stir the ice water in the Dewar with the supplied stainless-steel stirrer for 5 minutes. Record the temperature of the ice water once per minute. The temperature should be a steady 0.00 ± 0.01 C. If the temperature is not steady, speak to your TA. Record the temperature when steady.

8. Empty the Dewar and add about 300 mL of the 0.25 M chloroacetic acid solution to the Dewar. Again add about 100 mL of ice, and begin to stir the mixture vigorously. After 5 minutes of mixing, begin to record the temperature once per minute for 5 minutes. When the temperature is steady for 5 minutes, record the temperature.
9. Without delay withdraw about 10 mL of the chloroacetic acid solution and add to the empty and clean weighing bottle. Put the weighing bottle aside, and let the bottle equilibrate to room temperature for at least 45 minutes. If the weighing bottle is not at room temperature, moisture will condense on the outside of the bottle affecting the weight.
10. Determine the mass of a second clean and dry weighing bottle.
11. Empty and clean the Dewar. Dilute 150 mL the chloroacetic acid solution to approximately 0.125 M (a total volume of 300 mL). Add the diluted chloroacetic acid solution to the Dewar, and repeat steps 8 and 9.
12. Determine the mass of the weighing bottle containing the first solution. Empty the solution in the weighing bottle into the provided flask. Rinse the weighing bottle with deionized water several times emptying the waste into the flask.
13. Titrate the solution in the flask with the standardized sodium hydroxide solution. Remember to record the initial and final volumes of the sodium hydroxide level in the burette as well as the concentration of the stock solution.
14. Determine the mass of the second weighing bottle containing the dilute chloroacetic acid solution. Repeat step 13 for the dilute solution.

20.3 Calculations

1. Calculate the molality of all solutions. Recall that molality is the moles of solute per kg of solvent. The moles of solute are determined from the titration part of the experiment, and the mass of water is determined by subtracting the mass of solute from the total mass of the solution.
2. Calculate the degree of dissociation (i.e. the fraction dissociated) α for chloroacetic acid at both concentrations using Eqs. (1) and (2) on page 188 of the textbook. Calculate the equilibrium constant at both concentrations.
3. Calculate g_1 for chloroacetic acid and compare with the value of g_1 for an ideal nonionic solution.

20.4 Error Analysis

1. Use error propagation to determine the errors in the degree of dissociation and the equilibrium constant for chloroacetic acid. You should assume the error in each temperature measurement is ± 0.01 C, the error in each mass measurement is ± 0.0002 g and the errors in the volumes recorded from the burette are ± 0.05 mL. Remember to use the addition/subtraction formula to propagate errors for all differences.

20.5 Discussion

1. For chloroacetic acid do the computed equilibrium constants obtained at the two concentrations agree within experimental error?
2. Use the equilibrium constant of chloroacetic acid determined at the highest concentration to calculate the degree of dissociation expected at the lower concentration. Does your computed value agree with your measured degree of dissociation to within experimental error?
3. Calculate the pK_a of chloroacetic acid (along with the error in the pK_a) at both concentrations. Compare with literature values, and discuss any differences you find outside your computed errors.

21 Experiment 6 - The Heat of Combustion of Organic Compounds

21.1 Reading Assignment

Experiment 3(6), Pages 65-71, Text.

21.2 Experimental Notes

1. Follow the instructions in the textbook for the Parr instrument.
2. Our pressure gauge is calibrated in atmospheres. You must convert psi to atmospheres as discussed in the textbook.
3. You will determine the enthalpy of combustion for the compound assigned to you by your TA in class.

21.3 Error Analysis

In determining the error in the enthalpy of combustion of your compound, include contributions only from a) the mass of the iron wire used, b) the mass of the sample used, c)

the energies of combustion given in the text [± 2 in the last significant figure] and d) the temperature change. It will be necessary to determine the error in the heat capacity of the calorimeter from your first measurement, and then use this error by propagation to determine the error in the final molar enthalpy of combustion. You may ignore any errors from the volume of water used in filling the calorimeter, and you may ignore any errors in the determination of the time of measurement. These errors are so small that they are insignificant for our purposes.

22 Experiment Number 3(3) - Heat Capacity Ratio of Gases

22.1 Reading Assignment

Read experiment number 3(3), pages 51-59 in the text. The discussion that follows is somewhat different and more complete than the discussion in the textbook.

22.2 Theoretical Discussion

To determine the ratio $\gamma = C_p/C_V$, a carboy is filled with some gas at an initial pressure p_1 , and initial temperature T_1 and an initial volume V_1 . The initial pressure is generally about 60mm in excess of the external atmospheric pressure. After an equilibration period where the initial pressure is found to be unchanged for several minutes, the stopper at the top of the carboy is removed for about 1 second and replaced. It is assumed the rapidity that the stopper is removed and replaced allows the gas to expand adiabatically against the external atmospheric pressure p_2 to an intermediate volume V_2 and a temperature T_2 . Because the expansion is adiabatic, we know that $T_2 < T_1$. Finally, the gas heats at constant volume to the initial temperature T_1 so that the final pressure is p_3 . The experimental data consist of the pressures p_1 , p_2 and p_3 .

- Assumption of Reversibility: According to the textbook, the adiabatic expansion can be viewed as reversible. Assuming reversibility the determination of γ follows from the standard expressions for the adiabatic expansion of an ideal gas. Because the expansion is adiabatic and assumed reversible, we have

$$dU = -pdV = -\frac{nRT}{V}dV. \quad (42)$$

For an ideal gas

$$dU = C_V dT \quad (43)$$

so that

$$-nRd \ln V = C_V d \ln T. \quad (44)$$

Then for the first step in the process

$$-nR \ln \frac{V_2}{V_1} = C_V \ln \frac{T_2}{T_1}. \quad (45)$$

Using the ideal gas law we have

$$\frac{p_2 V_2}{T_2} = \frac{p_1 V_1}{T_1} \quad (46)$$

so that

$$\frac{T_2}{T_1} = \frac{p_2 V_2}{p_1 V_1}. \quad (47)$$

Then

$$-nR \ln \frac{V_2}{V_1} = C_V \ln \frac{p_2 V_2}{p_1 V_1} = C_V \ln \frac{p_2}{p_1} + C_V \ln \frac{V_2}{V_1}. \quad (48)$$

Using the ideal gas relation

$$C_p = C_V + nR \quad (49)$$

we then obtain

$$-C_p \ln \frac{V_2}{V_1} = C_V \ln \frac{p_2}{p_1}. \quad (50)$$

In the second step of the process we heat the gas at constant volume to a final state defined by the variables p_3 , V_2 and T_1 . For this constant volume process the ideal gas law along with Eq. (47) give

$$\frac{T_2}{T_1} = \frac{p_2 V_2}{p_1 V_1} = \frac{p_2}{p_3} \quad (51)$$

so that

$$\frac{V_2}{V_1} = \left(\frac{p_1}{p_2} \right) \left(\frac{p_2}{p_3} \right) = \frac{p_1}{p_3}. \quad (52)$$

Then

$$-C_p \ln \frac{p_1}{p_3} = C_V \ln \frac{p_2}{p_1} \quad (53)$$

or

$$\gamma = \frac{C_p}{C_V} = \frac{\ln(p_1/p_2)}{\ln(p_1/p_3)}. \quad (54)$$

- **Irreversible Adiabatic Expansion:** We now (perhaps more realistically) assume that the adiabatic expansion is an irreversible expansion of the gas against the constant external atmospheric pressure p_2 . Equating the irreversible work to the energy change for an ideal gas, we obtain

$$C_V(T_2 - T_1) = -p_2(V_2 - V_1) \quad (55)$$

$$= -p_2 \left(\frac{nRT_2}{p_2} - \frac{nRT_1}{p_1} \right) \quad (56)$$

$$= -nR \left(T_2 - T_1 \frac{p_2}{p_1} \right) \quad (57)$$

or

$$C_V \left(\frac{T_2}{T_1} - 1 \right) = -nR \left(\frac{T_2}{T_1} - \frac{p_2}{p_1} \right). \quad (58)$$

Using Eq. (47)

$$C_V \left(\frac{p_2 V_2}{p_1 V_1} - 1 \right) = -nR \left(\frac{p_2 V_2}{p_1 V_1} - \frac{p_2}{p_1} \right). \quad (59)$$

The second step in the irreversible process is the same as the reversible case, and we can again use Eq.(52) to obtain

$$C_V \left(\frac{p_2 p_1}{p_1 p_3} - 1 \right) = -nR \left(\frac{p_2 p_1}{p_1 p_3} - \frac{p_2}{p_1} \right) \quad (60)$$

or from Eq.(49)

$$C_V \left(\frac{p_2}{p_3} - 1 \right) = -(C_p - C_V) \left(\frac{p_2}{p_3} - \frac{p_2}{p_1} \right) \quad (61)$$

or

$$-(\gamma - 1) \left(\frac{p_2}{p_3} - \frac{p_2}{p_1} \right) = \left(\frac{p_2}{p_3} - 1 \right). \quad (62)$$

After rearranging Eq. (62) and solving for γ we obtain the final result

$$\gamma = \frac{p_1/p_2 - 1}{p_1/p_3 - 1}. \quad (63)$$

We can obtain Eq. (63) by expanding the numerator and denominator of Eq.(54) for small values of the argument. If we write

$$f(x) = \ln x \quad (64)$$

and expand f in a Taylor series about $x = 1$, we obtain

$$f(x) = f(1) + (x - 1)f'(1) + \frac{1}{2}(x - 1)^2 f''(1) + \dots \quad (65)$$

or

$$\ln x = (x - 1) + \dots \quad (66)$$

Then for $(p_1/p_2 - 1) < 1$ and $(p_1/p_3 - 1) < 1$ to leading order Eq.(54) becomes Eq.(63).

- Correct derivation allowing the escape of some of the gas: Let us now carefully derive Eq.(63). The steps in the process are:

1. an adiabatic irreversible expansion of the ideal gas from the state n_1, p_1, T_1 and V_1 against a constant external pressure p_2 to the final state n_1, p_2, T_2 and V_2 ;

2. use of the initial volume of the container so that the state of the system is represented by n_2, p_2, V_1 and T_2 - in this step some of the gas originally present is allowed to escape into the atmosphere;
3. constant volume heating to the initial temperature represented by the final state n_2, V_1, p_3 and T_1 .

We let C_V and C_p be the constant volume and constant pressure heat capacities *per mole*. Then for step 1

$$n_1 C_V (T_2 - T_1) = -p_2 \left(\frac{n_1 R T_2}{p_2} - \frac{n_1 R T_1}{p_1} \right) \quad (67)$$

$$= -n_1 R T_2 + n_1 R T_1 \frac{p_2}{p_1}. \quad (68)$$

Solving for T_2 we obtain

$$n_1 (R + C_V) T_2 = n_1 R T_1 \frac{p_2}{p_1} + n_1 C_V T_1 \quad (69)$$

or

$$C_p T_2 = R T_1 \frac{p_2}{p_1} + C_V T_1 \quad (70)$$

so that

$$T_2 = \frac{R}{C_p} T_1 \frac{p_2}{p_1} + \frac{C_V}{C_p} T_1 \quad (71)$$

$$= \frac{C_p - C_v}{C_p} T_1 \frac{p_2}{p_1} + \frac{C_V}{C_p} T_1 \quad (72)$$

$$= \left(1 - \frac{1}{\gamma} \right) T_1 \frac{p_2}{p_1} + \frac{1}{\gamma} T_1 \quad (73)$$

$$= \frac{T_1}{\gamma} \left[(\gamma - 1) \frac{p_2}{p_1} + 1 \right]. \quad (74)$$

In the second step, we remove $n_1 - n_2$ moles of gas from our system. The expression for n_2 is

$$n_2 = \frac{p_2 V_1}{R T_2} \quad (75)$$

$$= \frac{p_2 V_1}{R} \frac{\gamma}{T_1 \left[(\gamma - 1) \frac{p_2}{p_1} + 1 \right]}. \quad (76)$$

In step 3, the gas remaining in the initial volume is heated to temperature T_1 so that its final pressure is p_3 . Solving for p_3

$$p_3 = \frac{n_2 R T_1}{V_1} \quad (77)$$

$$= \left(\frac{RT_1}{V_1} \right) \left(\frac{p_2 V_1}{R} \right) \left(\gamma / \left\{ T_1 \left[(\gamma - 1) \frac{p_2}{p_1} + 1 \right] \right\} \right) \quad (78)$$

or

$$p_3 = \frac{p_2 \gamma}{(\gamma - 1) \frac{p_2}{p_1} + 1}. \quad (79)$$

We next rearrange Eq.(79)

$$(\gamma - 1) \frac{p_2}{p_1} + 1 = \gamma \frac{p_2}{p_3} \quad (80)$$

and solve for γ

$$\gamma \left(\frac{p_2}{p_1} - \frac{p_2}{p_3} \right) = \frac{p_2}{p_1} - 1 \quad (81)$$

or

$$\gamma = \frac{p_1/p_2 - 1}{p_1/p_3 - 1} \quad (82)$$

in complete agreement with Eq.(63).

22.3 Experimental Notes

1. The adiabatic expansion method is used. Follow the procedure outlined in the text.
2. Our experimental design uses an electronic open ended manometer. Readings from an open ended manometer gives the pressure relative to the atmospheric pressure. The atmospheric pressure must be obtained by reading the electronic barometer. Ask your TA for instructions.

22.4 Laboratory Report

1. Theory Section:
 - (a) Be sure to discuss the difference between the assumption of a reversible adiabatic expansion and an irreversible expansion against a constant external pressure. Explain which assumption is closest to the actual experimental situation.
2. Calculations:
 - (a) Calculate γ using both Eqs. (54) and (63).
3. Error Analysis:
 - (a) Assume an error of ± 2 in the last recorded figure from the electronic manometer and the electronic barometer.

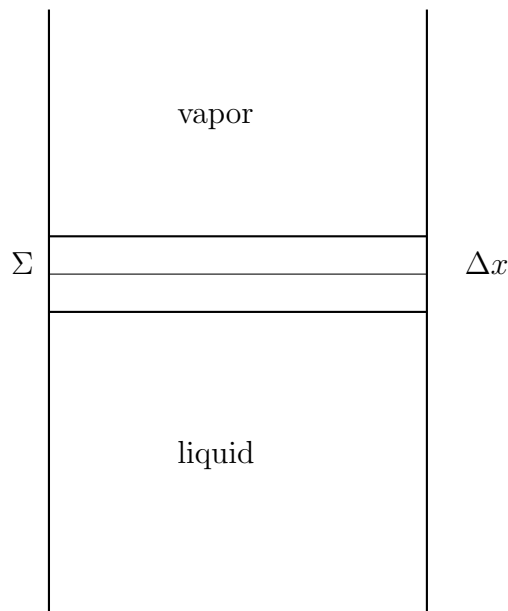

Figure 7: A representation of a container with a liquid mixture in equilibrium with a vapor phase. The section labelled Δx represents the surface region where the concentrations of both solvent and solute are not uniform. The horizontal line drawn at Σ represents the plane surface that defines the two-dimensional surface associated with the surface properties of the system.

- (b) Although the reported values of γ are obtained by an average of the heat capacity ratio for three trials, choose only 1 of the 3 trials for each gas to propagate the error in γ . Make sure to indicate carefully which of the three trials (for each gas) is used in your error propagation calculation. Carefully propagate errors in the pressure, the pressure ratios, the logarithms and the final ratios to obtain the propagated error in the heat capacity ratio. Compute expressions and values for the statistical error in γ from both Eqs. (54) and (63).

4. Conclusions:

- (a) Compare $\gamma \pm \epsilon(\gamma)$ using both the assumption of reversibility and irreversible adiabatic expansions. Do the two values determined lie within their respective statistical errors?
- (b) Compare $\gamma \pm \epsilon(\gamma)$ with the theoretical values expected for an ideal monatomic and diatomic gas. Do the theoretical results lie within your calculated experimental errors? If the results lie outside the experimental errors, discuss possible reasons for the lack of agreement.

23 Experiment 8(25) - Surface Tension of Solutions

subsectionReading Assignment

Textbook, Experiment number 8(25), pages 95-104.

23.1 Theory

1. Description of the system: We consider a system in a container consisting of a solute dissolved in a liquid solvent so that the solute has bulk concentration c_s , and we also

consider the situation where the solution has a surface of area σ . We take the surface to be in contact with a vapor phase (see Fig. 7). We assume the external temperature T and pressure P are fixed. While the solute has uniform density throughout most of the liquid phase, there is a small volume in the vicinity of the surface (represented by Δx in Fig. 7) where the solute and solvent concentrations decay to their vapor-phase concentrations. The concentration in the vapor phase is sufficiently low compared to the liquid phase that we can neglect further consideration of the contribution from the vapor phase to the surface properties. Figure 8 is a representation of the solute and solvent concentrations as a function of distance roughly within Δx . The x axis of Fig. 8 represents the vertical distance such that negative coordinates that are large in magnitude are locations within the bulk liquid, and large positive values of x (i.e. > 10) are in the vapor phase. The actual numerical values of x in the figure have no real meaning. The y axis of Fig. 8 gives the concentrations in arbitrary units for both the solvent and solute as marked. In Fig. 8 the bulk solute concentration is taken to be half of the solvent concentration, but the exact difference is unimportant for the current discussion. Of course we do require the solvent to have a greater bulk concentration than the solute. In the vicinity of the surface the solvent concentration decreases from its bulk value and the solute concentration increases. At $x = 10$ (arbitrary units) both the solute and solvent concentrations rapidly decay to their vapor phase values. In this experiment where we study a mixture of water (solvent) and butanol (solute), we have this behavior, which decreases the overall surface tension of the system. For other systems, like NaCl in water the solute concentration decreases near the surface and the solvent concentration increases.

2. Definition of the dividing surface: We next need to define a dividing surface that provides a sensible and useful meaning to the notion of the surface concentrations of solute and solvent in the region represented by Δx in Fig. 7. Shortly, we define the excess surface concentration of solute and solvent, and the units of the excess surface concentration are moles per unit area. The units imply that we can think of the solute and solvent molecules in Δx as residing on a two-dimensional planar surface, and we need to define our concepts so that the resulting definitions both give some physical insight and simultaneously are consistent with the number of moles of each species in the volume defined by Δx . The resulting definitions are physically artificial but mathematically consistent.

We draw a plane dividing surface within Δx , which we label Σ , and we choose the location of Σ so that the excess number of moles of solvent on each side of Σ is 0. To understand the notion of the excess number of surface moles of solvent, we let c_S be the bulk solvent concentration assumed to be uniform from the bottom of the container to the constructed surface at Σ . We let \bar{c}_S be the actual surface concentration that is uniform from the bottom of the container until we reach Δx and decays in Δx as we approach the vapor phase. The behavior of \bar{c}_S is depicted in Fig. 8. The excess number of moles of solvent is defined to be the difference between the deficit in the

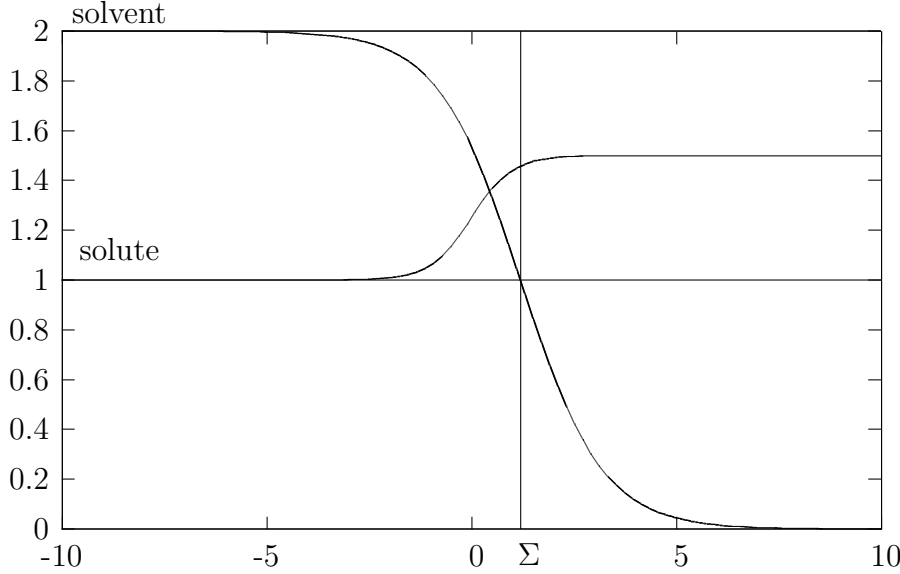

Figure 8: The concentration of the solvent and solute as a function of vertical distance (see Fig. 7) in the region Δx . The vertical line at Σ represents the constructed dividing surface. The horizontal lines at $y = 1$ and 2 (arbitrary units) correspond to the bulk solute and solvent concentrations respectively. The boundary at $x = 10$ (arbitrary units) is the end of the boundary region and corresponds to the interface between liquid and vapor.

number of moles of solvent obtained from \bar{c}_S compared to c_S below and above Σ . To make the concept clearer, we define the volume of the liquid phase, V_ℓ to be the volume of solution from Σ to the bottom of the container. Then the excess number of moles of solvent, n_S^Σ is defined to be

$$n_S^\Sigma = c_S V_\ell - \sigma \int_{-b}^{\Sigma} \bar{c}_S dx - \sigma \int_{\Sigma}^{\infty} \bar{c}_S dx \quad (83)$$

where $-b$ is the coordinate at the bottom of the container. We choose the location of Σ so that $n_S^\Sigma = 0$. This choice of the location of Σ implies

$$c_S V_\ell = \sigma \int_{-b}^{\infty} \bar{c}_S dx; \quad (84)$$

i.e. the total number of moles of solvent obtained by integrating the actual concentration profile over the entire system is identical to the number of moles that would be obtained if a uniform concentration existed up to the surface defined by Σ .

We define the excess number of moles of solute in the same manner used to define the solvent. Letting c_s be the bulk solute concentration assumed to be uniform throughout the solution and \bar{c}_s be the actual solute concentration, we write for the excess number of moles of solute

$$n_s^\Sigma = c_s V_\ell - \sigma \int_{-b}^{\Sigma} \bar{c}_s dx - \sigma \int_{\Sigma}^{\infty} \bar{c}_s dx. \quad (85)$$

While we have defined Σ so that $n_s^\Sigma = 0$ by construction, in general the different concentration profile for the solute implies that n_s^Σ cannot generally vanish.

As discussed above, we now associate (i.e. pretend) that all the excess number of moles of solute n_s^Σ are confined to a two-dimensional layer at Σ . We then define the *excess surface concentrations* of both the solute and solvent by

$$\Gamma_s = \frac{n_s^\Sigma}{\sigma} \quad (86)$$

and

$$\Gamma_S = \frac{n_S^\Sigma}{\sigma}. \quad (87)$$

By construction $\Gamma_S = 0$, and our goal is to measure Γ_s assuming all the excess number of moles of solute reside on the surface Σ . The measurement is possible by using the *Gibbs isotherm*.

Before deriving the Gibbs isotherm it is useful to understand the notion of excess surface concentration with some definite physical models. We consider the case where Δx consists only of a single layer of solute molecules adsorbed onto a solvent. Such films are called *monolayers*, and an example of such a system is oleic acid adsorbed on water. In such a case we place Σ just at the interface between the solvent and solute. Clearly, the excess surface concentration of solvent is 0, because the solvent molecules are completely absent from the monolayer. The resulting solute excess surface concentration is just the number of moles of solute in the monolayer per unit area. We see that our definition of excess surface concentration of solute is consistent with our expectations for a monolayer. In another limit we consider the case that solute and solvent are very similar (e.g. two completely miscible alcohols). In such a case Γ_s can be expected to be very small; i.e. very little solute needs to be associated with our artificial surface layer, because the concentration profiles of both solute and solvent in Δx have nearly the same functional form.

In the intermediate case between the two extremes outlined in the previous paragraph, the excess number of moles of solute can either be enhanced or diminished compared to $c_s V_\ell$. Work is required to form the surface owing to the breaking of bonds at the interface (e.g. the hydrogen bonds for liquid water), and solutes having weaker bonds than the solvent tend to have positive excess surface concentrations (e.g. butanol). Using similar reasoning solutes having stronger bonds than the solvent tend to have negative excess surface concentrations (e.g. sodium chloride).

3. The Gibbs Isotherm: We let G_v be the Gibbs free energy of the vapor phase, G_ℓ be the Gibbs free energy of the liquid phase and G_Σ be the Gibbs free energy of the surface phase. We allow all three phases to contain both solvent and solute. We can write for the total differential of the entire Gibbs free energy function

$$dG = dG_v + dG_\ell + dG_\Sigma. \quad (88)$$

In each phase G is a function of T, P and the number of moles of both the solvent and solute. Additionally, G_Σ depends on the surface area σ . We can then write (at fixed temperature and pressure)

$$dG = \mu_s dn_{v,s} + \mu_S dn_{v,S} + \mu_s dn_{\ell,s} + \mu_S dn_{\ell,S} + \mu_s dn_{\Sigma,s} + \mu_S dn_{\Sigma,S} + \gamma d\sigma. \quad (89)$$

where $n_{v,s}$ represents the number of moles of solute in the vapor, $n_{v,S}$ represents the number of moles of solvent in the vapor, $n_{\ell,s}$ represents the number of moles of solute in the liquid, $n_{\ell,S}$ represents the number of moles of solvent in the liquid, $n_{\Sigma,s}$ represents the number of moles of solute associated with the surface region, $n_{\Sigma,S}$ represents the number of moles of solvent associated with the surface region, and γ is the reversible work per unit area to form the surface; i.e. the surface tension. In the vapor and liquid phases alone, we know that

$$dG_v = \mu_s dn_{v,s} + \mu_S dn_{v,S} \quad (90)$$

and

$$dG_\ell = \mu_s dn_{\ell,s} + \mu_S dn_{\ell,S} \quad (91)$$

so that Eq. (89) becomes

$$dG_\Sigma = \mu_s dn_{\Sigma,s} + \mu_S dn_{\Sigma,S} + \gamma d\sigma. \quad (92)$$

Because the number of moles of each species and the surface area are all extensive variables with the chemical potentials and the surface tension intensive variables, by Euler's theorem on homogeneous functions we can write

$$G_\Sigma = \mu_s n_{\Sigma,s} + \mu_S n_{\Sigma,S} + \gamma \sigma. \quad (93)$$

After taking the total differential of Eq. (93) and subtracting Eq. (92), the result is a Gibbs-Duhem relation

$$-\sigma d\gamma = n_{\Sigma,s} d\mu_s + n_{\Sigma,S} d\mu_S. \quad (94)$$

or solving for the differential of the surface tension

$$-d\gamma = \Gamma_s d\mu_s + \Gamma_S d\mu_S \quad (95)$$

where we have recognized the excess surface concentrations as the number of moles of solute or solvent per unit area. As noted previously $\Gamma_S = 0$ by construction, and we know that

$$\mu_s = \mu^\circ + RT \ln a_s \quad (96)$$

where a_s is the activity of the solute defined so that the form of the chemical potential matches the ideal gas form. We can also write the activity in terms of the solute concentration

$$a_s = c_s \phi_s \quad (97)$$

where ϕ_s is called the activity coefficient. The activity coefficient can be shown to approach unity as the concentration of solute becomes low. Taking the differential of the chemical potential

$$d\mu_s = RT d \ln a_s \quad (98)$$

and substituting the differential into Eq. (95), we obtain

$$-d\gamma_s = RT \Gamma_s d \ln a \quad (99)$$

or

$$\Gamma_s = -\frac{1}{RT} \frac{d\gamma}{d \ln a_s}, \quad (100)$$

which is the Gibbs isotherm. The excess solute surface concentration Γ_s depends on the slope of the surface tension with solute activity, and to the extent that the relation between the surface tension and the logarithm of the activity is linear, we can assume the excess solute concentration is independent of total concentration. Consequently, the Gibbs isotherm can provide a single excess solute surface concentration for all total solution concentrations. The location of the dividing surface Σ does vary with concentration, but the location of Σ is not important to the overall interpretation.

In the textbook Eq. (100) is approximated by replacing the activity with the concentration; i.e. setting $\phi = 1$. Equation (100) enables the determination of the excess surface concentration of solute by measuring the surface tension as a function of concentration. We determine the excess surface concentration of solute in this manner in the current experiment.

23.2 Experimental Notes

1. We use the capillary rise method discussed in the textbook.
2. You make solutions of either *n*-butanol, iso-butanol, *sec*-butanol or *tert*-butanol. Ask your TA to assign the particular alcohol.
3. You are not to perform the NaCl experiment.
4. The approximately 0.8 M butanol stock solution will be provided. You are to use volumetric methods to prepare the other solutions.
5. Be sure to record the temperature of the bath.
6. The surface tension of distilled water as a function of temperature is given in the Table below. To determine the surface tension at your working temperature, you must use interpolation methods.

Temperature (°C)	surface tension of water (dy cm ⁻¹)
10.	74.23
20.	72.75
25.	72.00
30.	71.20

23.3 Laboratory Report

The laboratory report format is as follows:

1. Title Page: Give the title of the experiment, and the date the experiment was performed.
2. Abstract: This should be a 1 paragraph summary of what is to follow including the results. It is suggested that you write the abstract after the rest of the report is complete.
3. Introduction: This should be a discussion of the purpose of the experiment.
4. Theory: This should provide a derivation of the key formulas used in the experiment and in the data analysis section. Definitions must be provided for all symbols used in this and subsequent sections.
5. Procedure: Attach the outline of the procedure you brought to class and had signed by your TA.
6. Original Data: Attach the original data signed by your TA.
7. Data Table: Tabulate your data so that it can be used in the calculations to follow.

23.4 Calculations

1. We assume that the density of water and butanol solutions are the same and unchanging during the course of the experiment. We can then determine the surface tension of each solution, γ_s using

$$\gamma_s = \gamma_{H_2O} \frac{h_s}{h_{H_2O}} \quad (101)$$

where γ_{H_2O} is the surface tension of water obtained from the table, h_s is the capillary rise of the solution and h_{H_2O} is the capillary rise of pure water.

2. Be sure to calculate the surface concentration in both units of mol cm⁻² and molecules per square angstrom as discussed in your textbooks.

Activity Coefficient vs. Aqueous Concentration for Isomers of Butanol

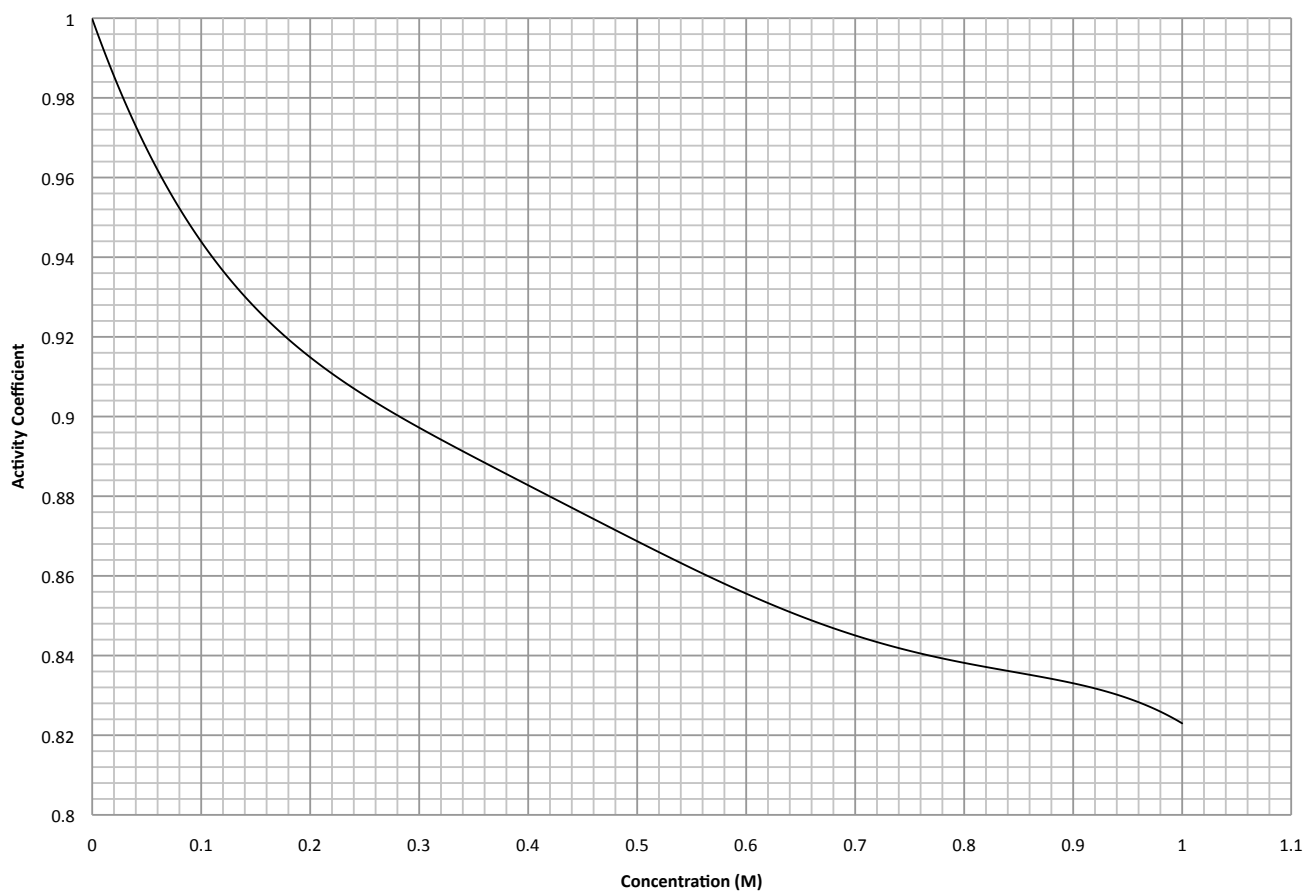

Figure 9: The activity coefficient of butanol as a function of concentration.

3. For the butanol calculations, use the activity coefficients given on page 302 of your textbooks. Alternatively, you can use the graph of the activity coefficient as a function of concentration given Fig. 9. You may use the same activity coefficients for all forms of butanol.
4. Error Analysis: Propagate the errors for only the first and last points on the graph of the surface tension as a function of the logarithm of the activity of the solution. Use the two calculated errors to determine the limiting slopes of your graph. Use the limiting slopes to estimate the error in your determined surface concentrations. Make sure to express the errors in both mol cm^{-2} and molecules \AA^{-2} . A conversion is required.

24 Tables of Data

ORGANIC LIQUIDS*
 N. ERNEST DORSEY

Viscosity of Water

FORMULAE AND UNITS

At a pressure of 1 atm., $\eta = a/(b + t)^2$.

At a pressure of P kg/cm², $\eta_p = \eta(1 + k_c(P - 1) \times 10^{-4})$.

η_1 is the value of η when P is 1 kg/cm², which may be taken as the value of η at 1 atm.

The unit of η is the poise unless otherwise stated.

WATER BETWEEN 0 AND 100°. I. C. T. VALUES

The following table was prepared from a critical evaluation of all available data. It is estimated that the accuracy is of the order of 0.1% between 0 and 40° and of 0.5 to 1% at higher temperatures. Linear interpolation may be safely employed throughout the table.

Values in millipoises (1, 12, 16, 17, 22, 24, 30, 31, 32, 38)

$t, ^\circ\text{C}$	0	1	2	3	4	5	6	7	8	9
0	17.938	17.320	16.740	16.193	15.676	15.188	14.726	14.288	13.872	13.476
10	13.097	12.735	12.390	12.061	11.748	11.447	11.156	10.875	10.603	10.340
20	10.087	9.843	9.608	9.380	9.161	8.949	8.746	8.551	8.363	8.181
30	8.004	7.834	7.670	7.511	7.357	7.208	7.064	6.925	6.791	6.661
40	6.536	6.415	6.298	6.184	6.075	5.970	5.868	5.770	5.675	5.582
50	5.492	5.405	5.320	5.236	5.153	5.072	4.994	4.918	4.843	4.770
60	4.699	4.629	4.561	4.495	4.431	4.368	4.306	4.245	4.186	4.128
70	4.071	4.016	3.962	3.909	3.857	3.806	3.756	3.708	3.661	3.615
80	3.570	3.526	3.483	3.440	3.396	3.357	3.317	3.278	3.240	3.203
90	3.166	3.130	3.095	3.061	3.027	2.994	2.962	2.930	2.899	2.869
100	2.839	2.82	2.79	2.76	2.73	2.70	2.67	2.64	2.62	2.59

ABSOLUTE DENSITY OF WATER

DENSITY IN GRAMS PER CUBIC CENTIMETER, COMPUTED FROM THE RELATIVE VALUES BY THIESEN, SCHEEL AND DISSELHORST (1900), AND THE ABSOLUTE VALUE AT 3.98° C. BY THE INTERNATIONAL BUREAU OF WEIGHTS AND MEASURES (1910).

Degrees	0	1	2	3	4	5	6	7	8	9
0	0.999841	847	854	860	866	872	878	884	889	895
1	900	905	909	914	918	923	927	930	934	938
2	941	944	947	950	953	955	958	960	962	964
3	965	967	968	969	970	971	972	972	973	973
4	973	973	973	972	972	972	970	969	968	966
5	965	963	961	959	957	955	952	950	947	944
6	941	938	935	931	927	924	920	916	911	907
7	902	898	893	888	883	877	872	866	861	855
8	849	843	837	830	824	817	810	803	796	789
9	781	774	766	758	751	742	734	726	717	709
10	700	691	682	673	664	654	645	635	625	615
11	605	595	585	574	564	553	542	531	520	509
12	498	486	475	463	451	439	427	415	402	390
13	377	364	352	339	326	312	299	285	272	258
14	244	230	216	202	188	173	159	144	129	114
15	099	084	069	054	038	023	007	*991	*975	*959
16	0.998943	926	910	893	877	860	843	826	809	792
17	774	757	739	722	704	686	668	650	632	613
18	595	576	558	539	520	501	482	463	444	424
19	405	385	365	345	325	305	285	265	244	224
20	203	183	162	141	120	099	078	056	035	013
21	0.997992	970	948	926	904	882	860	837	815	792
22	770	747	724	701	678	655	632	608	585	561
23	538	514	490	466	442	418	394	369	345	320
24	296	271	246	221	196	171	146	120	095	069
25	044	018	*992	*967	*941	*914	*888	*862	*836	*809
26	0.996783	756	729	703	676	649	621	594	567	540
27	512	485	457	429	401	373	345	317	289	261
28	232	204	175	147	118	089	060	031	002	*973
29	0.995944	914	885	855	826	796	766	736	706	676
30	646	616	586	555	525	494	464	433	402	371